

# PAMCO



**INNOVATION  
COMMITMENT  
TEAMWORK  
EXCELLENCE**

**PRECISION AIRCRAFT MACHINING CO., INC.**

10640 ELKWOOD STREET  
SUN VALLEY, CA. 91352

[WWW.PAMCO-INC.COM](http://WWW.PAMCO-INC.COM)

PHONE : (818) 768-5900  
FAX: (818) 768-1409



2015



# PAMCO

Precision Aircraft Machining co., inc.

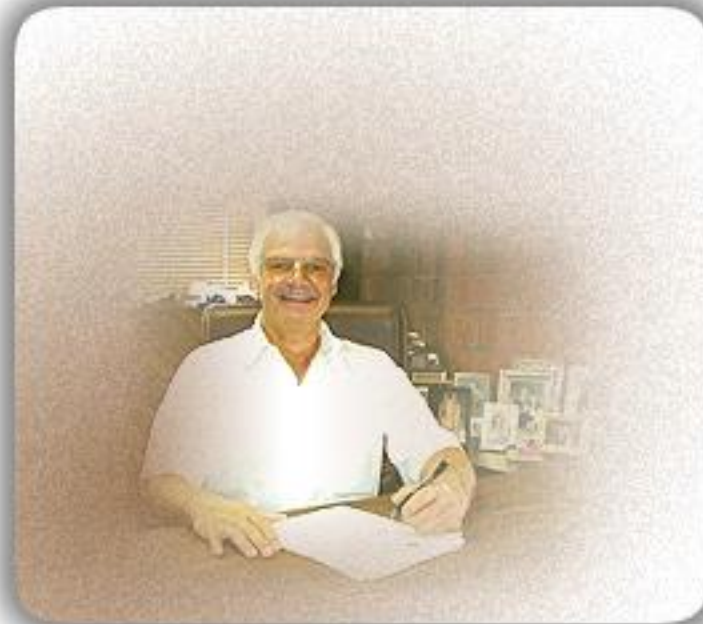

**“We are in business for our customers”**

Donald Pisano, President  
Precision Aircraft Machining Co., Inc.



WE ARE IN BUSINESS FOR OUR CUSTOMERS



## CONTENTS

<b>MESSAGE FROM PRESIDENT'S DESK</b>	<b>1</b>
<b>COMPANY OVERVIEW</b>	<b>3</b>
<b>HISTORY</b>	<b>5</b>
<b>WHAT IS NEW?</b>	<b>7</b>
<b>CUSTOMERS</b>	<b>10</b>
<b>MATERIALS</b>	<b>12</b>
<b>EQUIPMENT</b>	<b>14</b>
<b>PROCESSING</b>	<b>16</b>

<b>CAPABILITIES</b>	<b>18</b>
<b>MANUFACTURERS' RECOGNITIONS &amp; APPROVALS</b>	<b>21</b>
<b>CONTACT US</b>	<b>36</b>
<b>FREQUENTLY ASKED QUESTIONS</b>	<b>38</b>
<b>PARTS LISTING</b>	<b>41</b>
<b>REFERENCES</b>	<b>71</b>



**PAMCO**

PRECISION AIRCRAFT MACHINING CO., INC.

**PAMCO**

## Message *from* President's Desk

I would like to introduce you to PRECISION AIRCRAFT MACHINING CO. INC. dba PAMCO, a young aggressive, family owned, small business.

PAMCO is "Big enough to perform" on just about any size order but, "We're small enough to care" about our customers.

PAMCO has been continuously audited and Certified to AS9100, ISO 9001, AS7003, AC7112 and AC7112/2 since 2002 along with various other Primes.

With today's emphasis for quality and on time deliveries, PAMCO offers a modern high tech machine shop, which operates 20 hours a day and covers more than 22,000 square feet. PAMCO produces some of the finest products in today's marketplace with highly precision parts and rapid deliveries.

Our machine shop is supported by the Quality Assurance requirements of AS9100 Revision C, with first article, in process and final inspections. Our thread inspections meet all the requirements of AS 8879, MIL-S-7742, ANSI/AMSE A1.3M and handbook H-28. Inspection procedures also include the use of Laser Lab 3D version part inspection system, JOHNSON GAGES and optical comparators.

We manufacture AS, MS, NAS and AN hydraulic tube fittings, flared and flareless. We also manufacture Customer Proprietary Designs or Customer Controlled Standards and Specials. Alloys available are Titanium, Inconel, Monel, Carbon Steel, Aluminum and all Stainless Steels including 431, 15-5 PH and 17-4 PH.

Parts are made to order per customer request with small quantities of most part numbers maintained in stock. Pamco maintains an inventory of over 6,000 items. We manufacture parts for customers such as Boeing, Bell Helicopter, Textron, Lockheed Martin, Northrop Grumman, Litton Industries, Bombardier, Embraer, Gulfstream, Essex Cryogenics, Parker Stratoflex, Cessna Aircraft, Raytheon Aerospace, Beech Aircraft, Crane Resistoflex, DefenseSupplyCenter, Columbus (DSCC) and many others.

Lead times can vary from weeks to just days in the event of an AOG or a Customers critical need. Rush jobs or Expedited deliveries are always welcomed at PAMCO.

In our excellent short run shop we can run from just a few to hundreds in days instead of months.

We also carry a large inventory of raw material and forgings to be able to respond quickly. All material is DFAR compliant and certified.

Please call, fax or e-mail your requirements to our sales office and "Thank you" for taking time and allowing me to offer my company to you.

Sincerely yours,  
Donald A. Pisano, President  
Precision Aircraft Machining Co. Inc.

# PAMCO







PRECISION AIRCRAFT MACHINING CO., INC.

**PAMCO**

**PAMCO**

## Company Overview

In accordance with SAE Aerospace Standard AS7003, PAMCO was accredited since 2002 and granted inclusion into the Performance Review Institute's (PRI) Qualified Manufacturer List (QML) by the Nadcap Management Council PAMCO is also listed on the QML for the following Specifications:

- AS4444 Fittings, 24 degree Cone Flareless, Fluid Connection, 5000 psi
- AS4841 Fittings, 37 degree Flared, Fluid Connection
- AS4842 Fittings and Bosses, Pipe Threaded, Fluid Connection.
- AS4842/1 Fittings, 37° Flared to Pipe Threaded, Fluid Connection.
- AS4842/2 Fittings, Flareless to Flared to Pipe Threaded, Fluid Connection.
- AS4843 Fittings, Beaded, Fluid Connection.
- AS4843/1 Fittings, Beaded to 37 degree Flared, Fluid Connection.
- AS4843/2 Fittings, Beaded to Pipe Threaded, Fluid Connection.
- AS4875 Fittings, Straight Threaded Boss or Flanged, Fluid Connection.
- AS4875/1 Fittings, Straight Thread Boss or Flanged to 37 degree Flared, Fluid Connection.
- AS4875/2 Fittings, Flanged to Beaded, Fluid Connection
- AS18280 Fittings, 24 degree Cone Flareless, Fluid Connection, 3000 psi.
- AS85421 Fittings, Tube, Fluid Systems, Separable, Beam Seal, 3000/4000 psi.
- General Fittings and Other Machined Components

We manufacture AS, MS, NAS and AN hydraulic tube fittings, flared and flareless. Alloys available are Titanium, Inconel, Monel, Carbon Steel, Aluminum and all Stainless Steels including 431SS, 15-5 PH and 17-4 PH.

PAMCO has been certified thru PRI Registrar to AS9100C and ISO 9001 2008 in June 2012 and have been continuously since certified since 2002. In addition, PAMCO has been accredited to AC7112 and AC7112/2 since 2002.

PAMCO is a qualified source of, and is listed on the Performance Review Institute's (PRI) Qualified Products Listing (QPL) for the AS18280 Procurement Specification for Fittings, 24 degree Cone Flareless, Fluid Connection, 3000 psi. Below is a list of parts that PAMCO has been approved for as of January 2012 made out of Corrosion Resistant Steel, Titanium, Aluminum, 15-5 PH and Low Alloy Steel in bar and forging.

- QPL AS18280
- AS1001 thru AS1010, sizes -04 to -24
- AS1792, sizes -04 thru -20
- AS21900, sizes -04 thru -24
- AS21902, sizes -04 thru -24
- AS21904 thru AS21916, sizes -04 thru -24
- AS21921, sizes -04 thru -24
- AS21923 thru AS21926, sizes -04 thru -24
- AS21937 thru AS21945 sizes vary (\*see below)
- AS24405, sizes vary (\*see below)
- AS24651 thru AS24652, sizes -04 thru -24
- AS4130 thru AS4141, sizes -04 thru -24
- AS5230 thru AS5232, sizes -04 thru -24
- AS5238 thru AS5242, sizes vary (\*see below)
- AS6041 thru AS6050, sizes -04 thru -24
- QPL AS85421
- AS85421 /3 thru /17 in Titanium, sizes 04, 06, 08, 10
- AS4213 in Titanium, sizes 04, 06, 08, 10
- AS4214 in Titanium, sizes 04, 06, 08, 10

(\* Please contact PAMCO for your specific sizes)

We manufacture AS, MS, NAS and AN hydraulic tube fittings, flared and flareless. Alloys available are Titanium, Inconel, Monel, Carbon Steel, Aluminum and all Stainless Steels including 431, 15-5 PH and 17-4 PH.

PAMCO is continuously testing new part numbers so if you don't see a part number you're looking for, please contact PAMCO for the latest information.



**PAMCO**

PRECISION AIRCRAFT MACHINING CO., INC.

**PAMCO**

## History

If you ask Don Pisano, president and founder of PAMCO, to tell you about his company, he'll say, "Don't ask me about PAMCO... ask our customers." This one statement speaks volumes about the man and the company he created.

Don got interested in the aircraft business in the 1950s while working on Pratt & Whitney aircraft engines. He got a job modifying aircraft hardware in Sun Valley, California, where he learned the art of precision machining. A few years later, with money borrowed from a friend, Don started D.A. Pisano Company in his garage and continued working on P&W engine parts. In 1962, he moved his growing business into a small shop in Sun Valley where he ran his company for many years.

By 1979, Don and two partners were running a company called Cal Fittings, which bought and sold aircraft parts. Don wanted Cal Fittings to start manufacturing precision aircraft fittings, but his partners said, "No." Saying "No" to Don Pisano is like throwing down a gauntlet. Challenges are his inspiration for action. So Don set out to build another business...and PAMCO was born.

In that same year, PAMCO acquired manufacturing equipment for its recently completed 6,800-square-foot building in Sun Valley. With twelve employees, and Don's expert leadership, PAMCO began producing top-of-the-line-aircraft fittings. "The 1980s were tough years," says Don, "but hard work and close attention to customer needs saw us through and helped to create the success that is PAMCO today."

Indeed, PAMCO's success is amazing. PAMCO achieved Performance Review Institute's "Qualified Products Listing" (QPL) for -4, -5, -6, -8, -12, -16 & -20 and -24 in Aluminum, Stainless Steel, Low Carbon and Titanium materials starting in the early part of 2002 and still continuing today. This QPL is for flareless fittings procured under AS18280 (MIL-F-18280) requirements. PAMCO occupies over 22,000 square feet in Sun Valley, employs a work force of over 60, and operates 20-hours-a-day with two shifts.

What is the secret of PAMCO's success? "It's no secret," Don explains. "We just do things right. We're constantly looking for ways to improve our service to our customers. We plan to increase our QPL items in flareless fittings and expand our size ranges in our product line".

PAMCO's future is firmly rooted in its past. "Based upon our reputation alone," says Don, "we will maintain existing relationships as new business joins our family of loyal customers." PAMCO will continue to grow and prosper because, as Don likes to say, "We're not in business for ourselves ... we're in business for our customers."

Don's dedication and determination is instilled in each and every employee. From Management to Maintenance, from Machinist to Shipping Clerk, Quality and Customer come first.

# PAMCO





PRECISION AIRCRAFT MACHINING CO., INC.

**PAMCO**

**PAMCO**

What is new?

## **PAMCO IS APPROVED FOR AS85421 BEAM SEAL FITTINGS**

In December 2014 PAMCO was granted approval and accepted into SAE G3 Qualified Product Group (QPG) for the AS85421 BEAM SEAL STANDARD

PAMCO is pleased to announce inclusion into PRI Qualified Product Listing (QPL) for the Procurement Standard AS85421.

Please check with PAMCO for more additional information as we will be adding to this QPL listing soon.

## **PAMCO RECEIVES ISO 9001:2000 & AS/EN 9100-C CERTIFICATION**

Continuous since 2002, PAMCO has been Certified to SAE standard AS9100 and ISO9001.

AS9100 and ISO9001 Certifications are yet another step in the ongoing pursuit of excellence at PAMCO, and sets metrics in place for quality, production, cost accounting and many other aspects of modern business management.

These tools along with Don's expert leadership, sets PAMCO apart from the rest. It also sets the standard throughout PAMCO for increased efficiency and enhanced value as a result of AS9100. Let us show you what we can do for you.

In 2011, PAMCO joined with Performance Review Institute (PRI) Registrar to conduct our AS9100 and ISO9001 audits.

In May, 2012 PAMCO received AS9100 REV C and ISO9001 Certification through PRI REGISTRAR.

## **PAMCO RECEIVES AS7112 & AS7112/2 CERTIFICATION**

Since 2002, NADCAP's Management Council in accordance with SAE Aerospace Standard AS7003 has Accredited PAMCO to AC7112 (Accreditation Program Requirements for Fluid Systems Components) and AC7112/2 (Accreditation Program Requirements for Fittings and Other Machined Components). This Accreditation allows PAMCO inclusion into the Qualified Manufacturers List (QML) governed by Performance Review Institute (PRI) and is joined by only a handful of American Manufacturers that have attained this level of qualification.

In 2011, PAMCO joined with Performance Review Institute (PRI) Registrar to conduct our NADCAP audits.

In December of 2011, PAMCO was Re-Certified in accordance to AS7003 to maintain our QML status.

With PAMCO's commitment to the Quality and reliability of our fluid systems components, Qualifications and Re-Qualification Tests of products continuously, and Customer support we feel that PAMCO is your best choice. "PAMCO is big enough to perform but small enough to care".

Trust the team at PAMCO to deliver TOP QUALITY HARDWARE made to specification at VERY COMPETITIVE PRICES with DELIVERIES in WEEKS NOT MONTHS.

Please call, fax or email us today to see what we can do for you..

## PAMCO GOES ONLINE

<http://www.pamco-inc.com>

# PAMCO



WE ARE IN BUSINESS FOR OUR CUSTOMERS



**PAMCO**

PRECISION AIRCRAFT MACHINING CO., INC.

**PAMCO**



Customers

PAMCO works closely with our US and international customers to really understand their needs. Armed with this knowledge, we strive to produce some of the finest fittings in today's marketplace with highly precision parts and rapid deliveries.

Some of our customers include:

- Boeing Aircraft Company
- Lockheed Martin
- Fairchild
- Bombardier
- Canada Air
- De Haviland
- Auburn Technologies



- Embraer Air
- Flowserve
- Teleflex
- Titeflex
- Stratoflex
- Cessna Aircraft
- Beech Aircraft
- Litton Life Support
- Raytheon
- Allied Signal
- Honeywell
- Sikorsky
- Bell Helicopter Textron

# PAMCO





PRECISION AIRCRAFT MACHINING CO., INC.

**PAMCO**

**PAMCO**



Materials

In order to meet and exceed customer expectations, PAMCO consistently makes improvements and will continue to produce some

of the finest fittings with superior quality. All materials are DFAR complaint and certified. Some of the common materials

for bar, plate and forgings of our products include but not limited to:

### **ALUMINUM ALLOYS**

- 2014-T6 per AMS 4121, AMS4133
- 2024-T6 per AMS-QQ-A-225/6 or AMS4339
- 2024-T851 per AMS-QQ-A-225/6 or AMS4339
- 6061-T6 per QQ-A-225/8
- 6061-T651 per AMS4117
- 7075-T73 per QQ-A-225/9 or AMS4141
- 7075-T7351 per AMS4124
- 2024-T351 or T4 wire per AMS-QQ-A-225/6 or AMS 4120

## STAINLESS STEEL ALLOYS

- 15-5PH per AMS5659
- 17-4PH per AMS5643
- 300 Series Wire per ASTM-A-580, or AMS5637
- 300 & 400 Series per AMS-QQ-S-763, AMS5639, AMS5645, AMS5648 and AMS-S-18732
- A286 per AMS 5732 or AMS5737

## AIRCRAFT STEEL ALLOYS

- 4130 per AMS6370
- 4140 per AMS5626
- 12L14 per ASTM-A-108
- C1137 per ASTM-A-108

## BRASS ALLOYS

- Alloy 360 Half Hard
- Alloy 377

## TITANIUM

- 6AL-4V per AMS4928 and AMS4965

## ALUMINUM ALLOY CASTINGS

- ASTM-B-108-99

If you don't see the material or material specification you're looking for, please contact PAMCO for assistance.

# PAMCO





PRECISION AIRCRAFT MACHINING CO., INC.

**PAMCO**

**PAMCO**

Equipment

### **CNC TURNING MACHINES**

- (1) Nakamura-Tome TW-20MM CNC Lathes • 10.6" x 7.6" Cap
- (3) Nakamura-Tome TW-20 CNC Lathes • 10.6" x 7.6" Cap
- (4) Nakamura-Tome TW-10MM CNC Lathe • 8.3" x 6.1" Cap
- (3) Nakamura-Tome TW-10 CNC Lathe • 8.3" x 6.1" Cap
- (2) Takisawa TC-350 L5 CNC Lathes • 10.8" x 20.1" Cap
- (2) Takisawa TC-20 CNC Lathes • 9.5" x 12.0" Cap
- (3) Takisawa TCC 2000 CNC Lathes
- (2) Takisawa TCN 2000 CNC Lathes
- (2) Takisawa TCN 2500 CNC Lathes
- (1) Daewoo Puma 8S CNC Lathe • 14.1" x 14.6" Cap

### **CNC MILLING MACHINES**

- (2) Brother S700 X 1 CNC Machining Center
- (1) Fadal VMC-15 CNC Mill • 20.0" x 16.0" x 20.0" xyz Cap

## MANUAL MACHINES

- (1) Andes Engine Lathe • 12.0" dia Cap
- (1) Webb Enging Lathe • 17.0" x 40.0" Cap
- (8) Crozier Speed Lathes • 1.0" dia Cap
- (4) EMI-MEC Auto Sprint Series E Automatic Chuckers

## SUPPORT EQUIPMENT

- (1) Chicago Drill Press • 5 Speeds
- (1) CTT Tool Radial Drill • 1.25" Cap
- (1) Duracraft Drill Press • 12 Speeds
- (1) Chicago Drill Press • 12 Speeds
- (1) Sunnen Honing Machine
- (4) Pedestal Tool & Cutter Grinders
- (2) Pedestal Diamond Wheel Grinders
- (2) Amada HA 250 Band Saws +A32
- (6) Burr-King Belt Sanders • 1.5" x 60.0"
- (3) Craftsman Belt Sander • 1.0" x 42.0"
- (2) UNI-Hone Bead Blasters
- (1) Hyster 4,000 lb Forklift

## QUALITY CONTROL SOFTWARE

- Gage Track

## 3D INSPECTION SYSTEM & OPTICAL COMPARTORS

- (1) Laser Lab 3D version part inspection system
- (1) Sherr Tumico Optical Comparator • 50x
- (2) Micro-Vu Optical Comparators • 50x

## OTHERS

- (1) Flexbar Phase II Hardness Tester
- (1) Standridge Surface Plate • 36.0" x 48.0" • Grade AA
- (1) Surface Plate • 18.0" x 24.0" • Grade AA
- (1) Fowler Gage Block Set • Grade (3)
- (1) Set Meyer Gage Pins • .011 thru .832 dia
- (3) Mitutoyo Height Gages • .001" thru 12.0"
- Johnson External Thread Gages • 3/8-20 (-3) thru 3 1/2-12 (-48)
- Johnson External Thread Gages • 7/16-20 (-4) thru 1 7/8-12 (-24)
- MTG Internal Thread Gages • 5/16-24 (-2) thru 3 1/2-12 (-48)
- Assorted Class 2A & Class 3A Ring Gages
- Assorted Class 2B & Class 3B Plug Gages
- Assorted ANPT & ANPF Pipe Ring Gages
- Assorted ANPT & ANPF Pipe Plug Gages
- Assorted Standard & Digital Micrometers & Calipers



SION AIRCRAFT MACHINING CO., INC.

**PAMCO**

**PAMCO**



Processing

- Alodine
- Anodizing
- Cadmium Plating
- Dry Film Lubricant
- Epoxy Painting
- Fluoride Phosphate Coat
- IVD Coating
- Passivating & Cleaning

# PAMCO



WE ARE IN BUSINESS FOR OUR CUSTOMERS



SION AIRCRAFT MACHINING CO., INC.

**PAMCO**

**PAMCO**

Capabilities

## **PAMCO PRODUCTS ARE MADE-TO-ORDER**

PAMCO's modern, high-tech machine shop operates twenty hours a day and produces the finest products in today's marketplace. PAMCO recognizes your requirements for quality and on-time delivery.

PAMCO manufactures AN, MS, AS, & NAS hydraulic tube fittings, both flared and flareless. Alloys available include Inconel, Monel, Titanium, Stainless Steel, Aluminum, Carbon Steel, Brass and Copper alloys. PAMCO also manufactures specials or part-to-print in all the same materials.

All PAMCO parts are made-to-order per customer request. Small quantities of most items are maintained in stock. Rush or expedited orders are welcome in PAMCO's short run shop where parts are made in days instead of months. Please call or fax your fitting requirements to our sales department.

PAMCO manufactures AN, MS, AS and NAS standards as well as metric fittings, parts to print and customer controlled standards and specials.

PAMCO is AS18280 QPL approved, qualified for sizes 4 through 24 in carbon steel, stainless steel, aluminum and titanium. PAMCO is certified to and operates to AS9100 and AS7003.

PAMCO is "Big enough to perform" on just about any size order but, "We're small enough to care" about our customers.



## THE PAMCO QUALITY POLICY

Precision Aircraft Machining Co., Inc. shall strive to deliver the products and services that meet or exceed the customer's requirements. PAMCO shall commit to constant improvement by training its people, upgrading equipment, eliminating non-essential practices, and creating an environment of quality consciousness. This policy is implemented and carried out at all levels in the organization.

## QUALITY FORGINGS AVAILABLE FROM PAMCO

PAMCO maintains a large inventory of high-quality forgings as raw material for its products. These forgings are available for sale in a variety of materials and configurations for subsequent machining. All forgings are DFAR compliant and certified. Certifications and test reports are available for each lot of forgings. PAMCO forgings are procured only from high-quality sources with approved quality control procedures. Call PAMCO for more information.

# PAMCO



# PAMCO





PRECISION AIRCRAFT MACHINING CO., INC.

**PAMCO**

**PAMCO**

Manufacturers' Recognitions  
& Approvals

### **ISO 9001:2000 & AS/EN 9100 APPROVALS**

Boeing, Lockheed Martin, Gulfstream Aero, Cessna Raytheon Beach, Embraer, Bombardier, DSCC, Bell Helicopter, Textron, Crane Resistoflex, Parker Stratoflex, Essex Cryogenics.



The Performance Review Institute

December 4, 2014

Mr. Bill Andersen  
Floor Manager  
PAMCO, Inc.  
10640 Elkwood Street  
Sun Valley, California 91352-4631

Dear Mr. Andersen:

Subject: G3-F223 – PAMCO, Inc. – AS85421 – Sizes 4, 6, 8, 10 – Titanium ONLY

We are pleased to advise that the PAMCO request for qualification for the following parts has been accepted by the G3 Qualified Product Group (QPG) in support of your organization's inclusion on the PRI Qualified Product Listings for the following standards.

AS85421

Part Standard	PAMCO Part Number	Sizes	psi	Alloy and Temper
AS85421/3	PBS421/3	04, 06, 08, 10	4000	Titanium
AS85421/4	PBS421/4	04, 06, 08, 10	4000	Titanium
AS85421/5	PBS421/5	04, 06, 08, 10	4000	Titanium
AS85421/6	PBS421/6	04, 06, 08, 10	4000	Titanium
AS85421/7	PBS421/7	04, 06, 08, 10	4000	Titanium
AS85421/8	PBS421/8	04, 06, 08, 10	4000	Titanium
AS85421/9	PBS421/9	04, 06, 08, 10	4000	Titanium
AS85421/10	PBS421/10	04, 06, 08, 10	4000	Titanium
AS85421/11	PBS421/11	04, 06, 08, 10	4000	Titanium
AS85421/12	PBS421/12	04, 06, 08, 10	4000	Titanium
AS85421/13	PBS421/13	04, 06, 08, 10	4000	Titanium
AS85421/14	PBS421/14	04, 06, 08, 10	4000	Titanium
AS85421/15	PBS421/15	04, 06, 08, 10	4000	Titanium
AS85421/16	PBS421/16	04, 06, 08, 10	4000	Titanium
AS85421/17	PBS421/17	04, 06, 08, 10	4000	Titanium
AS4213	PBS4213	04, 06, 08, 10	4000	Titanium
AS4214	PBS4214	04, 06, 08, 10	4000	Titanium

Please note that if PAMCO, Inc. requires qualification approval for AS85421/# size 12, a new project will have to be initiated in the [www.eAuditNet.com](http://www.eAuditNet.com) system.

As the manufacturer of a qualified product, your organization will appear on the PRI Qualified Products List (QPL) at [www.eAuditNet.com](http://www.eAuditNet.com). As a condition of your continued qualification, there will be an annual listing fee. PRI will invoice you annually for your listing. In addition to the listing fee, the specification for each QPL defines supplemental requirements.

Americas  
+ 1 724 772 1616

Asia

Europe  
+44 870 350 5011

[www.pri-network.org](http://www.pri-network.org)

Headquarters: 161 Thorn Hill Road, Warrendale, PA 15086-7527 USA

060471





Network Procurement  
2007 Award Winner

The Stratoflex Products Division of Parker Hannifin Corporation

*hereby recognizes*

**PRECISION AIRCRAFT MACHINE COMPANY INC**

*AS A STRATEGIC PARTNER*

The Network Procurement Agreement Award is in recognition of suppliers that meet the six (6) elements of the agreement: Quality, Technology, Minimum Order Quantity, Lead Times, The Process of Continuous Improvement, and Pricing. The Overall Value NP Suppliers provide Parker supports the continuing effort to maintain our position as the Global Leader in Motion and Control Technologies.

A handwritten signature in black ink, appearing to read "Alfonso Solis".

Alfonso Solis, *Division Procurement Manager*

A handwritten signature in black ink, appearing to read "Brian Lovejoy".

Brian Lovejoy, *Division Quality Manager*

**ENGINEERING YOUR SUCCESS.**



Lockheed Martin Aeronautical Systems  
86 South Cobb Drive Marietta, GA 30063



March 5, 1996

Precision Aircraft Machining Co  
(PAMCO)  
10640 Elkwood Street  
Sun Valley, CA 91352-4631

Attention: Jim Asseltyne

Subject: APPROVAL OF MANUFACTURER'S DRAWING (AMD)

Reference: AMD # 96-33 Dated 2-15-96

LMASC Standards Engineering has approved your drawing for the part number(s) listed on the referenced AMD, and a copy of the AMD is enclosed for your records.

The drawing listed on the AMD have been approved as specifically set out. Any changes to the drawing not approved by LMASC Standards Engineering will be cause for withdrawal of this approval.

Upon procurement of these parts, the purchase order "hold to" shall be the respectively listed revision of the drawing shown. Any FNN note listed shall also become a part of the "hold to." It should be noted that parts shipped to a revision level other than the level called out in the purchase order may be considered non-conforming and will be subject to return.

It is requested that five (5) copies of the drawing listed be forwarded to:

LOCKHEED MARTIN AERONAUTICAL SYSTEMS COMPANY  
MARIETTA, GEORGIA 30063  
ATTENTION: VENDOR DATA FILES  
DEPARTMENT 82-13, ZONE 0364

If you have any questions, please call me.

Very truly yours,

LOCKHEED MARTIN AERONAUTICAL SYSTEMS COMPANY

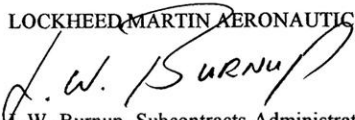
  
L.W. Burnup, Subcontracts Administrator  
Standard Parts/MSP Group  
Dept. 55-45, Zone 0510

Encls.

LOCKHEED MARTIN



**MCDONNELL DOUGLAS**

McDonnell Douglas Aerospace

05 February 1993

Mr. Gene Mundy  
Quality Control Manager  
10640 Elkwood Street  
Sun Valley, CA 91352

Subject: Recognition of PAMCO's Support on the F-15E Program

Dear Mr. Mundy:

The F-15E Molecular Sieve Oxygen Generating System (MSOGS) requires that the system meet stringent leakage requirements. During initial implementation of MSOGS, it was determined that the standard AN fittings were inadequate to provide the proper sealing capability.

MDA-E and Litton-ILSD requested that PAMCO design and develop a standard fitting that could meet the system's leakage requirements. PAMCO developed and tested a 37 degree lipseal fitting that surpassed the required system leakage rates.

MDA-E would like to thank PAMCO for their commitment to excellence on the F-15E MSOGS program. PAMCO's dedication in providing a quality product, on time, was instrumental towards the program's success. Your continuing support to the F-15E MSOGS program is appreciated.

Again, thank you for a job well done!



Brad Korte  
Sr. Engineer, Design  
F-15 Crew Station  
Sta. 35897, M/C 0343190

CONCUR:



I. P. Gaira  
Unit Manager  
F-15 Design  
Sta. 31608, M/C 0343190

P.O. Box 516, Saint Louis, MO 63166-0516 (314) 232-0232 Telex 44-857

**MCDONNELL DOUGLAS**

DIVISION OF BOEING

**MCDONNELL DOUGLAS**

McDonnell Douglas Aerospace

WILLIAM L. STOWERS  
Vice President  
Supplier Management and Procurement - East

700-296  
03 March 1993

PAMCO  
10640 Elkwood St  
Sun Valley, CA 91352

Attention: Mr. Jim Asseltyne

Subject: **MDA PREFERRED SUPPLIER CERTIFICATION AWARD**

Dear Jim:

McDonnell Douglas Aerospace (MDA) is pleased to inform you that PAMCO has earned Preferred Supplier Certification Status. This achievement is based on PAMCO meeting an overall Bronze Level certification. PAMCO has attained Bronze Level for Business Processes, Bronze Level for Quality, Silver Level for Delivery Performance, and Bronze Level for SPC. Retention of preferred certified status will require PAMCO to maintain performance to at least the minimum standards of certification. However, MDA wishes to encourage you to strive for the Gold Level of Preferred Certification Status.

We would like to make a formal presentation at your plant at a time that is convenient for you. For planning purposes, I have designated Darwin Seidel to coordinate the arrangements for this presentation. Darwin may be contacted at (314) 232-6818. Please advise alternate dates so that we can determine a mutually convenient schedule.

Once again, congratulations on achieving this award. MDA appreciates the outstanding efforts of the PAMCO Team, and we look forward to a constantly improving long-term relationship.

Sincerely,



William L. Stowers - Vice President  
Supplier Management and Procurement

P.O. Box 516, Saint Louis, MO 63166-0516

**MCDONNELL DOUGLAS**

DIVISION OF BOEING





**UNITED  
SUPPLY  
COMPANY**

Manufacturers of Aerospace Tube Fittings

November 13, 1995

To: All Aerospace Purchasing Agents, Buyers, Standards  
Engineers, and Quality Assurance Managers

From: Richard M. Barkley, President  
United Supply Co., Inc.

Subject: SALE OF UNITED SUPPLY CO. PART SERIES

United Supply Co. is pleased to announce that Precision Aircraft Machining Company, Inc. dba PAMCO has been selected as the sole authorized manufacturer of all US, UFR, UR, UV, UVD and UT series parts and as such is the sole-owner of all trademarks, copyrights, etc., pursuant to the manufacture and sale of the entire United Supply part series.

PAMCO is an excellent manufacturer, in the tradition of United Supply Co. and has a superior reputation for quality parts delivered to schedule. I recommend that all of United Supply's customers give PAMCO an opportunity to provide top quality parts and support.

Very truly yours,

UNITED SUPPLY CO., INC.

Richard M. Barkley, President

RNB/jp



**UNITED  
SUPPLY  
COMPANY**

Manufacturers of Aerospace Tube Fittings

WE ARE IN BUSINESS FOR OUR CUSTOMERS



**SCOPE OF ACCREDITATION**

**Fluid Distribution Systems**

**PAMCO**  
10640 Elkwood St  
Sun Valley, CA 91352-4631

This certificate expiration is updated based on periodic audits. The current expiration date and scope of accreditation are listed at: [www.eAuditNet.com](http://www.eAuditNet.com) - Online QML (Qualified Manufacturer Listing).

In recognition of the successful completion of the PRI evaluation process, accreditation is granted to this facility to perform the following:

**AC7112 Rev A - Nadcap Fluids Systems Manufacturers Audit Criteria**

**AC7112/2 Rev A - Nadcap Audit Criteria for Fittings and Other Machined Components**

AS18280  
AS4370  
AS4444  
AS4841  
AS4843  
AS4843/1  
AS4843/2  
AS4875  
AS4875/1  
AS4875/2  
AS85421  
AS85720

tfrm-17

17-Jun-10





*In accordance with SAE Aerospace Standard AS7003, to the revision in effect at the time of the audit, this certificate is granted and awarded by the authority of the Nadcap Management Council to:*

## **PAMCO**

10640 Elkwood St  
Sun Valley, CA 91352-4631  
United States

*This certificate demonstrates conformance and recognition of accreditation for specific services, as listed in [www.eAuditNet.com](http://www.eAuditNet.com) on the Qualified Manufacturers List (QML), to the revision in effect at the time of the audit for:*

### **Fluid Distribution Systems**

Certificate Number: 4024157694  
Expiration Date: 30 April 2017

Joseph G. Pinto  
Vice President and Chief Operating Officer

Performance Review Institute (PRI) | 161 Thorn Hill Road | Warrendale, PA 15086-7527





# Certificate of Registration



This is to certify that  
**Precision Aircraft Machining Company, Inc. "PAMCO"**  
Controlling/Central Function: **10640 Elkwood Street, Sun Valley, CA 91352**  
**10641/10649 Elkwood Street, Sun Valley, CA 91352**  
**7826 Clybourn Street, Sun Valley, CA 91352**  
**7838/7832 Clybourn Street, Sun Valley, CA 91352**  
**USA**

is registered as a Campus quality management system  
demonstrated in conformance with

**ISO 9001:2008 and AS9100-C**

The audit was conducted in accordance with the requirements of SAE AS9104/1:2012-01  
PRI Registrar is accredited under the ICOP Scheme

**Scope of Registration:**

**Controlling Address (Central Function): 10640 Elkwood Street –**  
Manufacture of Hydraulic Fittings, Specialty Fittings and Machined Parts to  
system certified to AS9100 and ISO 9001:2008;

Excluding Design and Post-delivery Support 7.5.1.4a, c, d, e.

**10641/10649 Elkwood Street - CNC Machining, Deburring.**

Excluding Design and Post-delivery Support 7.5.1.4a, c, d, e.

**7826 Clybourn Street - CNC Machining, Deburring.**

Excluding Design and Post-delivery Support 7.5.1.4a, c, d, e.

**7838/7832 Clybourn Street - CNC Machining, Deburring.**

Excluding Design and Post-delivery Support 7.5.1.4a, c, d, e.



*Peter P. Kucan, Jr.*  
Peter P. Kucan, Jr. – Director – Registrar Operations

Number: 13-2018R  
Issued: 6/10/2014  
Expires: 6/10/2017

PR0300

Performance Review Institute • 161 Thorn Hill Road • Warrendale, PA 15086-7527 • Phone 724.772.1616



WE ARE IN BUSINESS FOR OUR CUSTOMERS

**AEROSPACE INDUSTRIES ASSOCIATION**



**Certificate of Associate Membership**

This is to certify that

**PRECISION AIRCRAFT  
MACHINING COMPANY**

Qualified for and has been accepted as a  
**MEMBER OF THE SUPPLIER MANAGEMENT COUNCIL**  
2007-2008

  
\_\_\_\_\_  
John W. Douglass  
President & CEO, AIA

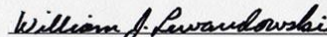
  
\_\_\_\_\_  
William J. Lewandowski  
Vice President, Supplier Management





# Gulfstream

A GENERAL DYNAMICS COMPANY

## Approval Of Supplier

Gulfstream Aerospace is pleased to grant its' approval to

### Precision Aircraft Machining Co., Inc.

as a supplier of material, parts, and/or services. This approval is given after a complete facilities survey and examination of the Quality Control/Assurance organization has been accomplished. You are approved to provide to Gulfstream Aerospace Corporation the various categories of material, parts and/or services as listed here.

### Manufacturing of Fluid Fittings

This approval is given subject to your continued compliance with Gulfstream Aerospace Corporation Supplier Quality Assurance Requirements as defined by contract.

DATE 22 March 2010

- EXPIRES
- 1 YEAR FROM DATE
  - 3 YEARS FROM DATE
  - 4 YEARS FROM DATE
  - UNTIL RESCINDED

*[Handwritten Signature]*

Gulfstream Aerospace Corporation  
QUALITY ASSURANCE DEPARTMENT  
P.O. BOX 2206 A-03  
SAVANNAH, GEORGIA 31402-2206

# Gulfstream

A GENERAL DYNAMICS COMPANY

**NORTHROP GRUMMAN**



Sector Director  
Supplier Assurance & Commodity Engineering

Aerospace Systems  
Northrop Grumman Corporation  
One Hornet Way  
El Segundo, CA. 90245-2804  
Telephone 310-332-1446

K08J6Q-10-183

September 13, 2010

Precision Aircraft Machining Co Inc.  
10640 Elkwood St  
Sun Valley, CA 91352-4631

Attn: Mr. Donald Pisano, President

**Subject: Platinum Level – Platinum Source Plaque**

On behalf of Northrop Grumman Aerospace Systems Sector we are pleased to present this plaque to Precision Aircraft Machining Co Inc. for their sustained excellence as a supplier of quality products and on-time delivery.

**Congratulations to you and your employees!**

Sincerely,

A handwritten signature in black ink that reads "SR Moe".

Steven R. Moe, Director  
Supplier Assurance & Commodity Engineering

**NORTHROP GRUMMAN**

WE ARE IN BUSINESS FOR OUR CUSTOMERS

# Platinum Award



**NORTHROP GRUMMAN**

*Given in recognition of*

*Sustaining Customer  
Quality & Delivery Expectations*

*Presented to*

**Precision Aircraft  
Machining Co. Inc.**

**September 1, 2010**

Handwritten signature of Lisa V. Kohl in blue ink.

Lisa V. Kohl  
Sector Vice President  
Global Supply Chain  
Aerospace Systems

Handwritten signature of Steven R. Moe in blue ink.

Steven R. Moe  
Director  
Supplier Assurance & Commodity Engineering  
Aerospace Systems

**NORTHROP GRUMMAN**





2007 Certified Supplier  
Stratoflex Products Division

*This is to certify that:*

**PRECISION AIRCRAFT MACHINE COMPANY INC.**

*is hereby granted certified supplier status in accordance with Parker Hannifin supplier quality assurance procedures. This status is subject to continued compliance with Parker Aerospace Group – Supplier Quality Assurance Requirements as defined by contract.*

A handwritten signature in black ink, appearing to read "Alfonso Sotis".

Alfonso Sotis, Division Procurement Manager

A handwritten signature in black ink, appearing to read "Brian Lovejoy".

Brian Lovejoy, Division Quality Manager

**ENGINEERING YOUR SUCCESS.**





PRECISION AIRCRAFT MACHINING CO., INC.

**PAMCO**

**PAMCO**

Contact Us

## **Precision Aircraft Machining Co., Inc.**

**10640 Elkwood Street  
Sun Valley, CA 91352**

**Phone: (818) 768-5900  
Fax: (818) 768-1409**

**[WWW.PAMCO-INC.COM](http://WWW.PAMCO-INC.COM)**

**[mail@pamco-inc.com](mailto:mail@pamco-inc.com)**

**DON PISANO**

President (x220)  
dpisano@pamco-inc.com

**KIM PISANO**

V.P. of Operations (x219)  
kpisano@pamco-inc.com

**JIM ASSELTyne**

Sales (x215)  
jasseltyne@pamco-inc.com

**JIM THOMSON**

Sales (x230)  
jthomson@pamco-inc.com

**BILL ANDERSEN**

General Manager (x216)  
bandersen@pamco-inc.com

**THOMAS COOK**

Quality Manager (x213)  
tcook@pamco-inc.com

Accounting (x214)  
accounting@pamco-inc.com

Certification (x212)  
invoice@pamco-inc.com

Follow-Up (x211)  
expediting@pamco-inc.com

**PAMCO**



WE ARE IN BUSINESS FOR OUR CUSTOMERS



PRECISION AIRCRAFT MACHINING CO., INC.

**PAMCO**

**PAMCO**

## Frequently asked questions

**Question:**

How long has PAMCO been in business?

**Answer:**

PAMCO was founded in 1979 and has been in continuous operation ever since.

**Question:**

Where is Sun Valley, California?

**Answer:**

Sun Valley, California, is located in the eastern San Fernando Valley, approximately 15 miles north of downtown Los Angeles.

**Question:**

What is the standard lead time at PAMCO?

**Answer:**

Depending upon the component requirements, PAMCO is often able to deliver your order in as little as a few days. Please call PAMCO to discuss your specific requirements.

**Question:**

What materials can PAMCO use to produce parts?

**Answer:**

PAMCO can produce its components in almost any available machineable metal including stainless steel, Inconel and Titanium. Please call PAMCO for your specific requirements.

PAMCO's staff can assist you with all of your special fitting requirements. Please call PAMCO for details.

**Question:**

How large is PAMCO's facility in Sun Valley, California?

**Answer:**

PAMCO maintains a 20,000-square-foot modern manufacturing facility in Sun Valley, California.

# PAMCO







## Parts listing





AS95

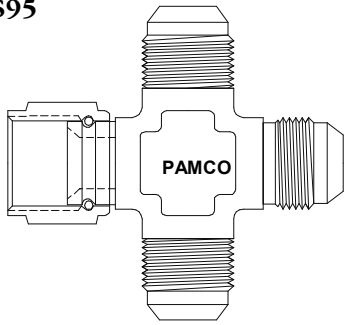

FITTING ASSEMBLY. CROSS

AS893

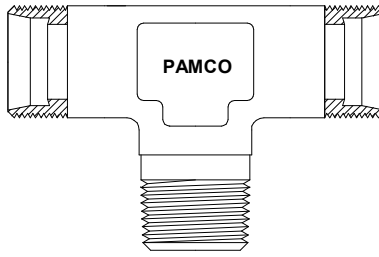

FITTING, TEE, STANDARD AND REDUCER

AS894

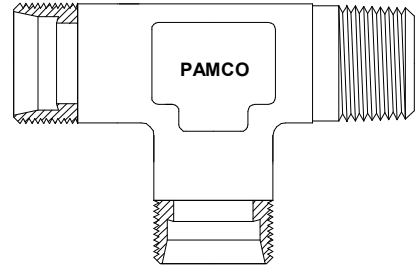

FITTING, TEE, STANDARD AND REDUCER

AS895

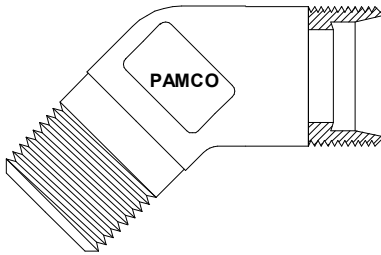

FITTING ELBOW, 45 DEGREE

AS896

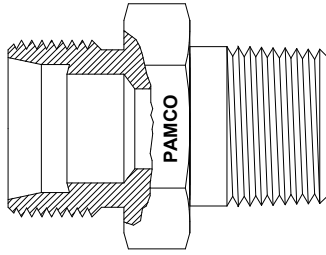

FITTING, NIPPLE, REDUCER

AS897

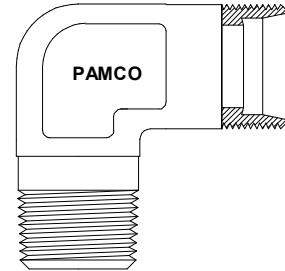

FITTING ELBOW, 90 DEGREE



PRECISION AIRCRAFT MACHINING CO., INC

PHONE : (818) 768-5900

FAX: (818) 768-1409

AS931

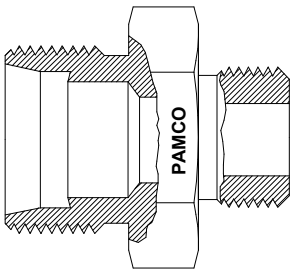

FITTING, ADAPTER, REDUCER/EXPANDER

AS932

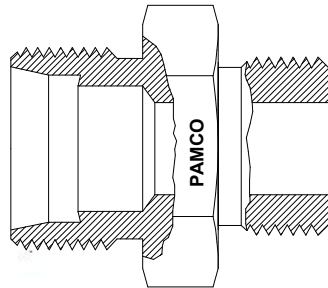

FITTING, ADAPTER, REDUCER/EXPANDER

AS933

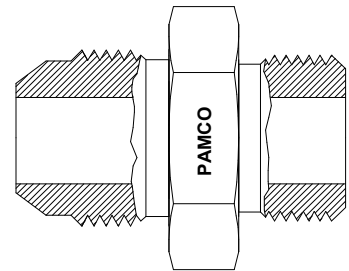

FITTING, ADAPTER, UNION

AS934

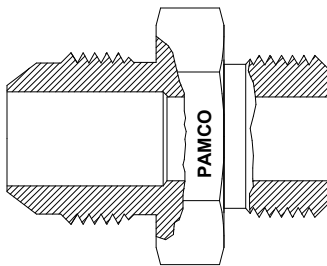

FITTING, ADAPTER, REDUCER/EXPANDER

AS1001

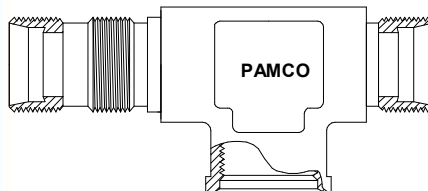

FITTING, TEE, STANDARD AND REDUCER

AS1002

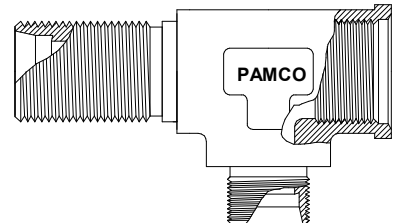

FITTING, TEE, STANDARD AND REDUCER



AS1003

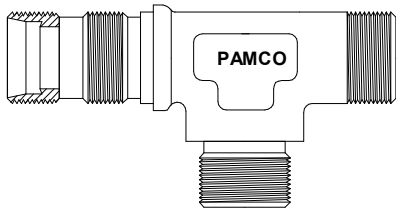

FITTING, TEE, STANDARD AND REDUCER

AS1004

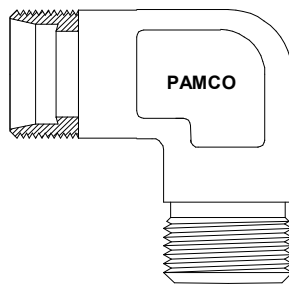

FITTING ELBOW, 90 DEGREE

AS1005

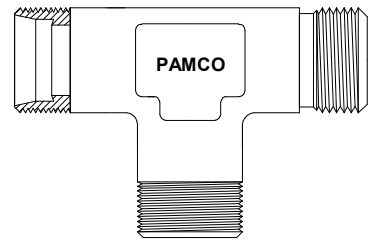

FITTING, TEE, STANDARD AND REDUCER

AS1006

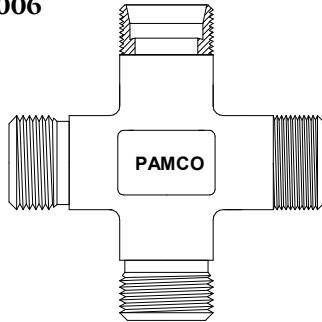

FITTING, CROSS, STANDARD AND REDUCER

AS1007

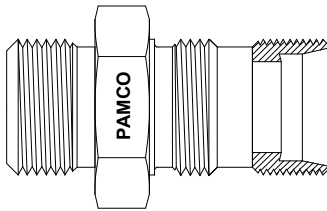

FITTING, UNION, STANDARD AND REDUCER

AS1008

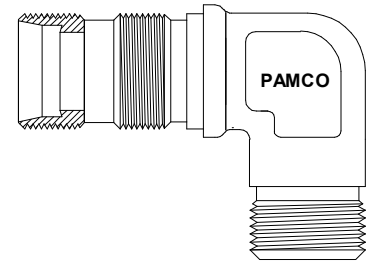

FITTING ELBOW, 90 DEGREE



PRECISION AIRCRAFT MACHINING CO., INC

PHONE : (818) 768-5900

FAX: (818) 768-1409

AS1009

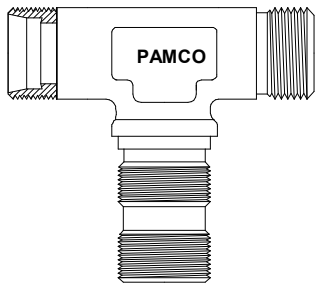

FITTING, TEE, STANDARD AND REDUCER

AS1010

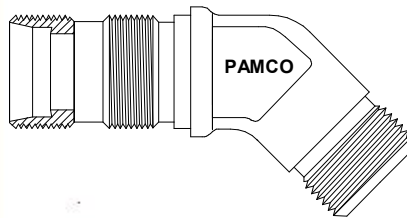

FITTING ELBOW, 45 DEGREE

AS1031

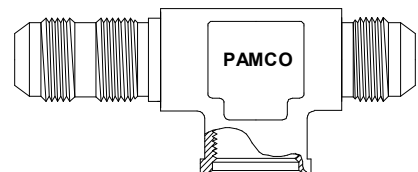

FITTING, TEE, STANDARD AND REDUCER

AS1032

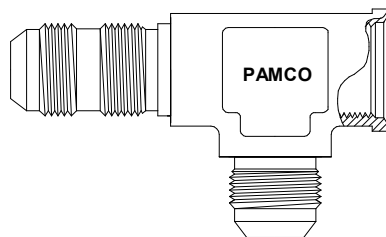

FITTING, TEE, STANDARD AND REDUCER

AS1033

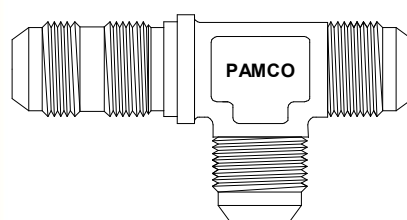

FITTING, TEE, STANDARD AND REDUCER

AS1034

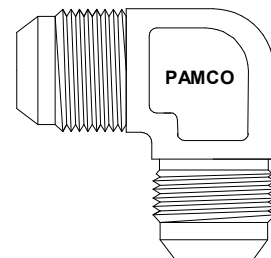

FITTING ELBOW, 90 DEGREE



AS1035

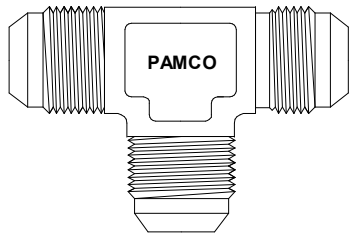

FITTING TEE, STANDARD & REDUCER, FLARED

AS1036

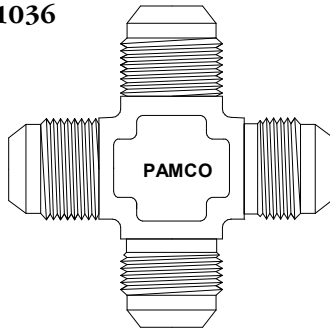

FITTING CROSS, STANDARD & REDUCER, FLARED

AS1037

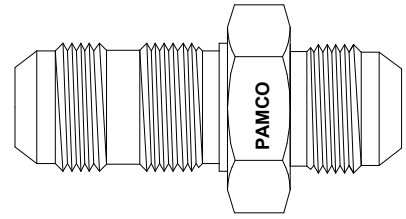

FITTING UNION, STANDARD & REDUCER, BULKHEAD

AS1038

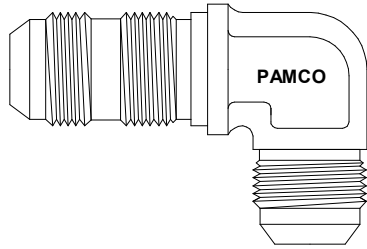

FITTING ELBOW, 90 DEGREE, STANDARD & REDUCER

AS1039

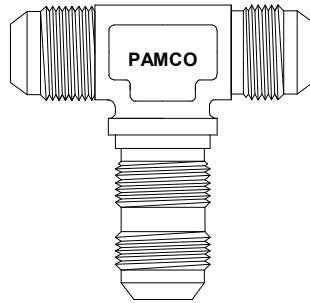

FITTING TEE, STANDARD & REDUCER, BULKHEAD

AS1040

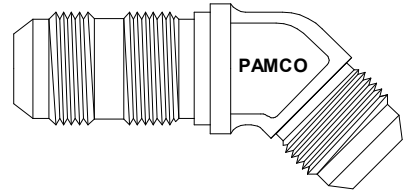

FITTING ELBOW, 45 DEGREE, STANDARD & REDUCER



PRECISION AIRCRAFT MACHINING CO., INC

PHONE : (818) 768-5900

FAX: (818) 768-1409

AS1100

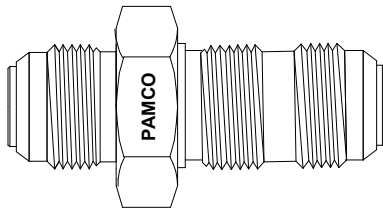

UNION, FLARED TUBE, BULKHEAD AND UNIVERSAL

AS1249

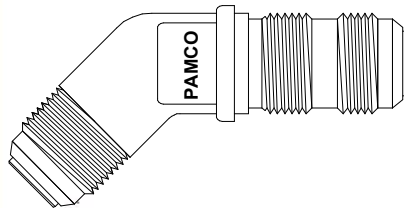

ELBOW, 90 DEGREE, FLARED TUBE FOR SEALING RING

AS1250

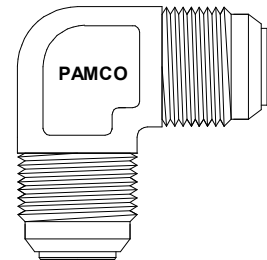

ELBOW, 90 DEGREE, FLARED TUBE FOR SEALING RING

AS1251

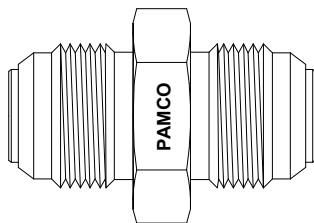

FITTING, UNION, FLARED TUBE FOR SEALING RING

AS1252

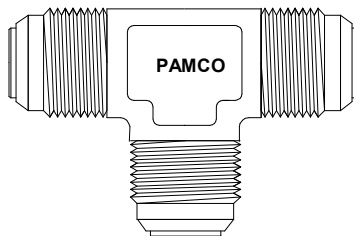

TEE, FLARED TUBE FOR SEALING RING

AS1253

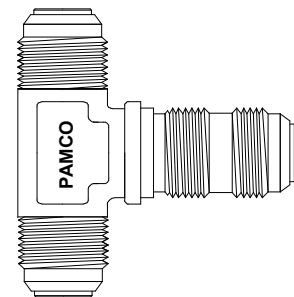

TEE, FLARED TUBE, BULKHEAD, FOR SEALING RING



AS1365

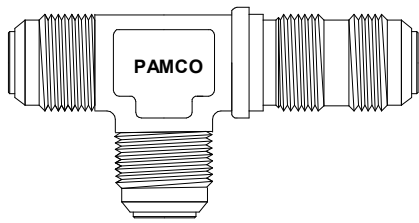

TEE, FLARED TUBE, BULKHEAD, FOR SEALING RING

AS1366

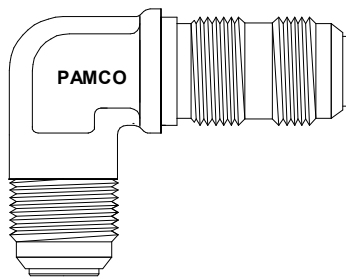

ELBOW, 90, FLARED TUBE, BULKHEAD, FOR SEALING

AS1367

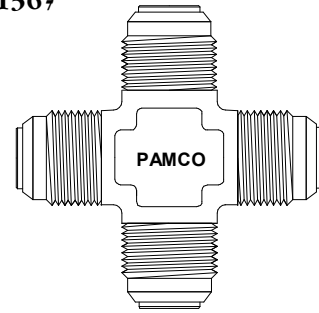

CROSS, FLARED TUBE, FOR SEALING RING

AS1368

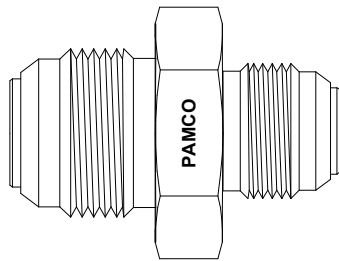

FITTING, REDUCER EXTERNAL, THREAD FLARED TUBE

AS1369

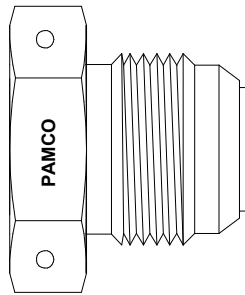

PLUG, FLARED TUBE, FOR SEALING RING

AS1581

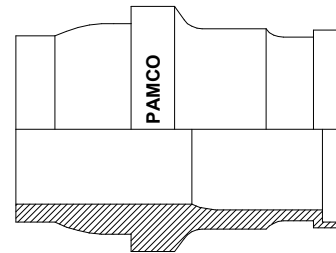

FITTING, SLEEVE, FLARELESS ACORN TO WELD RING



PRECISION AIRCRAFT MACHING CO., INC

PHONE : (818) 768-5900

FAX: (818) 768-1409

AS1582

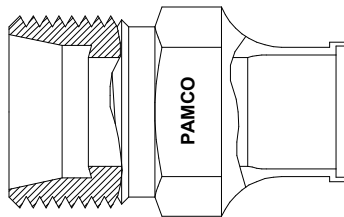

FITTING, ADAPTER, EXTERNAL THREAD, FLARELESS

AS1583

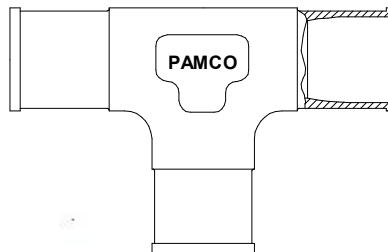

FITTING, TEE, INTEGRAL WELD RING

AS1584

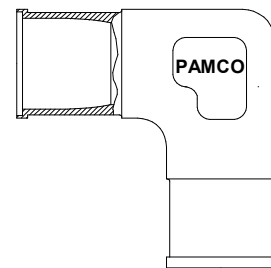

FITTING, ELBOW, 90, INTEGRAL WELD RING

AS1585

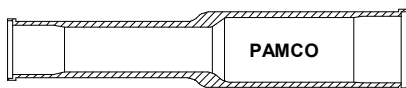

FITTING, REDUCER, INTEGRAL WELD RING

AS1732

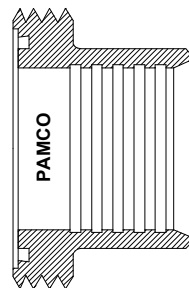

BODY, COUPLING, RIGID, FIXED CAVITY, THREADED

AS1790

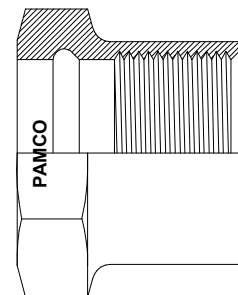

NUT, FITTING, RETAINED, LIGHTWEIGHT

WHEN QUALITY AND DELIVERY COUNT



AS1792

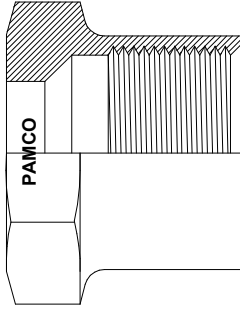

NUT, FITTING, LIGHTWEIGHT, FLARELESS



PRECISION AIRCRAFT MACHINING CO., INC

PHONE : (818) 768-5900

FAX: (818) 768-1409

WHEN QUALITY AND DELIVERY COUNT



AS21900

MS21900

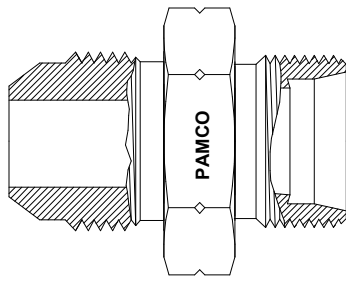

ADAPTER, FLARELESS TUBE TO A FLARED TUBE

AS21902

MS21902

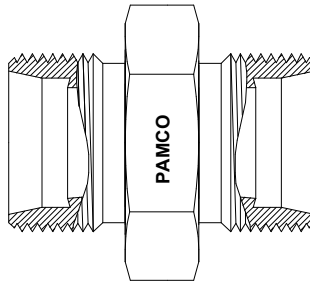

UNION, FLARELESS TUBE

AS21904

MS21904

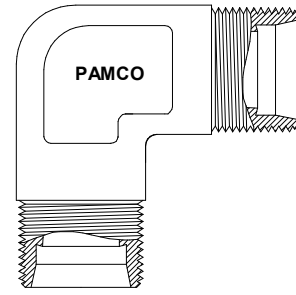

ELBOW, FLARELESS TUBE, 90

AS21905

MS21905

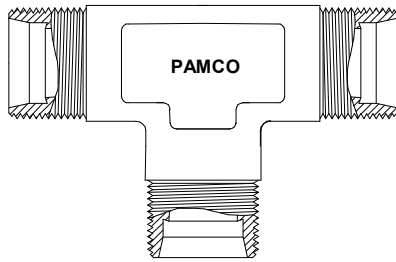

TEE, FLARELESS TUBE

AS21906

MS21906

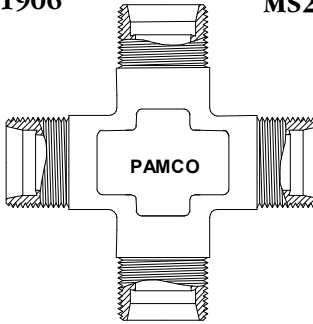

CROSS, FLARELESS TUBE

AS21907

MS21907

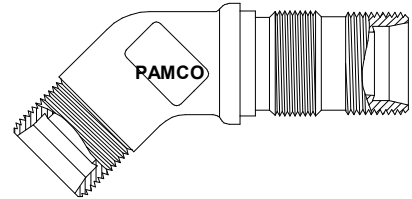

ELBOW, BULKHEAD UNIVERSAL, 45, FLARELESS TUBE



PRECISION AIRCRAFT MACHINING CO., INC

PHONE : (818) 768-5900

FAX: (818) 768-1409

AS21908

MS21908

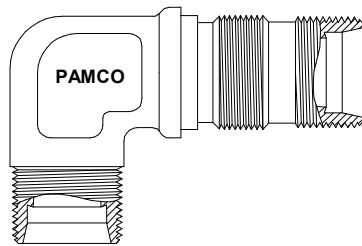

ELBOW, BULKHEAD & UNIVERSAL 90, FLARELESS TUBE

AS21909

MS21909

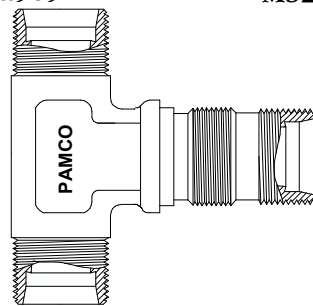

TEE, BULKHEAD & UNIVERSAL, FLARELESS TUBE

AS21910

MS21910

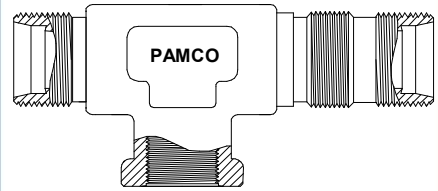

TEE, BULKHEAD, FLARELESS TUBE, INTERNAL THREAD

AS21911

MS21911

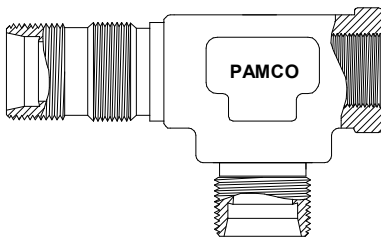

TEE, BULKHEAD, FLARELESS TUBE, INTERNAL THREAD

AS21912

MS21912

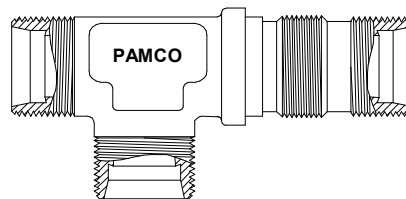

TEE, FLARELESS TUBE WITH BULKHEAD ON RUN

AS21913

MS21913

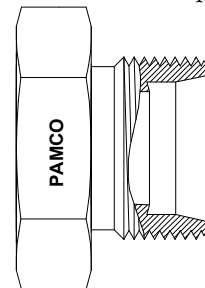

PLUG, FLARELESS TUBE



WHEN QUALITY AND DELIVERY COUNT

AS21914

MS21914

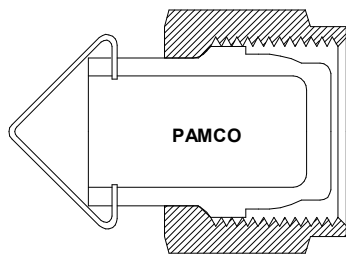

CAP. PRESSURE SEAL, FLARELESS TUBE FITTING

AS21915

MS21915

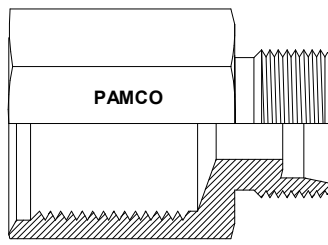

ADAPTER, STRAIGHT, TUBE BOSS

AS21916

MS21916

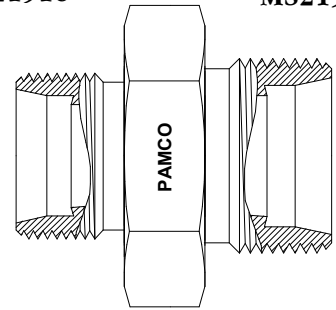

REDUCER, EXTERNAL, THREAD, FLARELESS TUBE

AS21921

MS21921

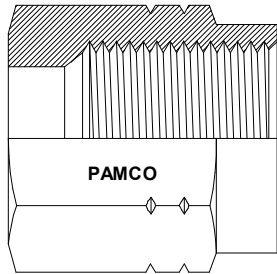

NUT, SLEEVE COUPLING, FLARELESS

AS21923

MS21923

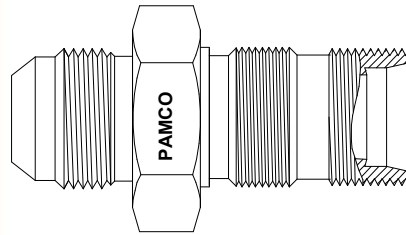

ADAPTER, FLARELESS TUBE, TO FLARED TUBE

AS21924

MS21924

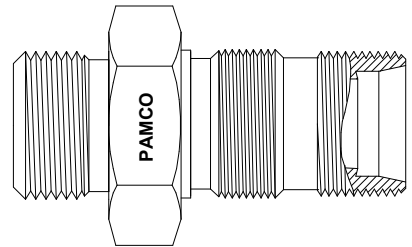

UNION, FLARELESS TUBE, BULKHEAD AND UNIVERSAL



PRECISION AIRCRAFT MACHINING CO., INC

PHONE : (818) 768-5900

FAX: (818) 768-1409

AS21925

MS21925

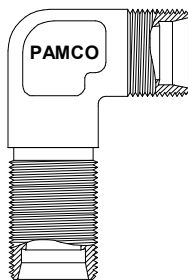

ELBOW 90, UNIVERSAL, FLARELESS TUBE, HIGH PROFILE

AS21926

MS21926

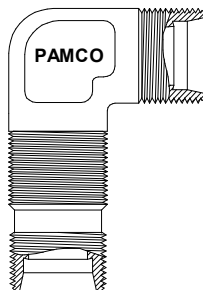

ELBOW 90, UNIVERSAL, FLARELESS TUBE, LOW PROFILE

AS21927

MS21927

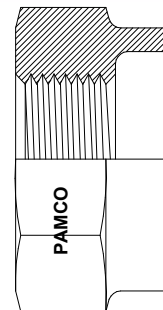

NUT, CLUSTER FITTING, RETAINER

AS21938

MS21938

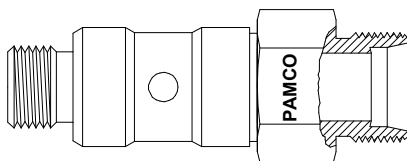

BOLT, CLUSTER FITTING, SINGLE PORT, FLARELESS

AS21939

MS21939

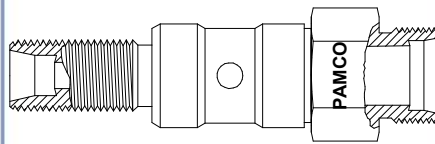

BOLT, CLUSTER FITTING, SINGLE PORT, THROUGH

AS21940

MS21940

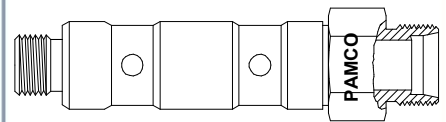

BOLT, CLUSTER FITTING, DOUBLE PORT, FLARELESS



AS21941

MS21941

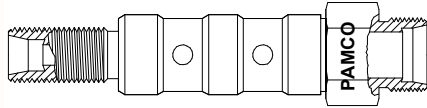

BOLT, CLUSTER FITTING, DOUBLE PORT, THROUGH

AS21942

MS21942

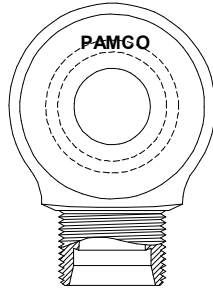

BODY, CLUSTER FITTING, ONE WAY, FLARELESS

AS21943

MS21943

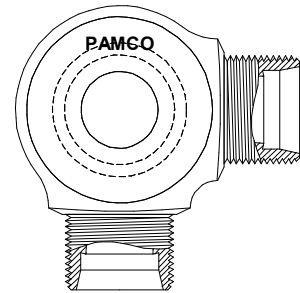

BODY, CLUSTER FITTING, TWO WAY, 90, FLARELESS

AS21944

MS21944

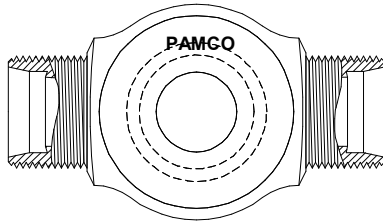

BODY, CLUSTER FITTING, TWO WAY, 180, FLARELESS

AS21945

MS21945

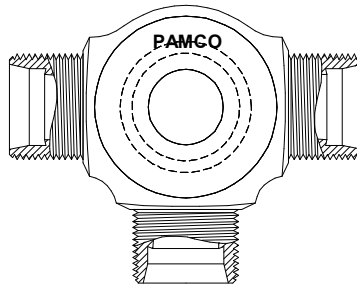

BODY, CLUSTER FITTING, THREE-WAY, FLARELESS



PRECISION AIRCRAFT MACHINING CO., INC

PHONE : (818) 768-5900

FAX: (818) 768-1409





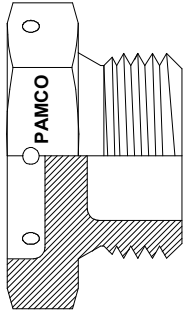

**AS3000**

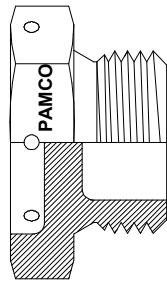

PLUG, MACHINE THREAD - AMS 5646, METAL GASKET

**AS3001**



SILVER PLATED

PLUG, MACHINE THREAD - AMS 5646, METAL GASKET

**AS3163**

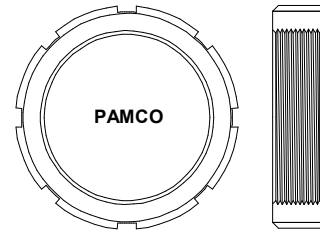

PLUG

**AS3166**

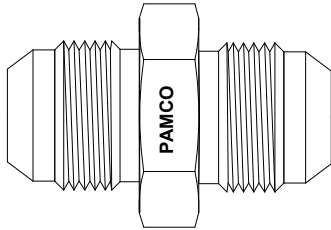

UNION, TUBE CRES AMS 5646 CONICAL END.

**AS3220**

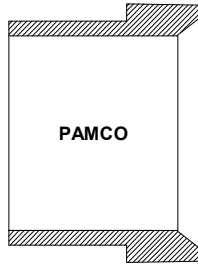

SLEEVE, FLARED, TUBE FITTING - ALUMINUM

**AS3226**

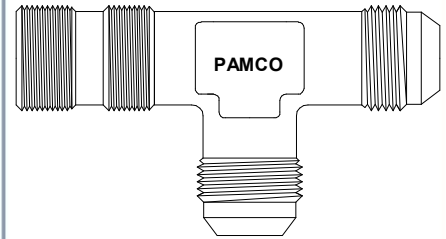

TUBE, TEE, BOSS - AMS 5646



**PRECISION AIRCRAFT MACHING CO., INC**

**PHONE : (818) 768-5900**

**FAX: (818) 768-1409**



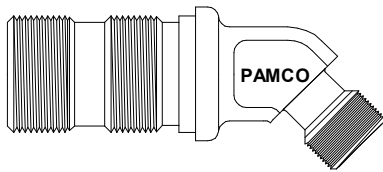

AS4130

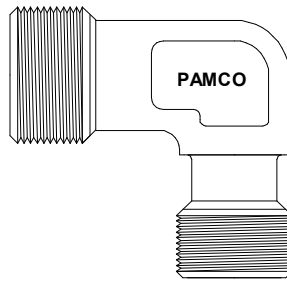

ELBOW, 45, BULKHEAD, REDUCED BODY, FLARELESS

AS4131



ELBOW, 90, REDUCED BODY, FLARELESS

AS4132

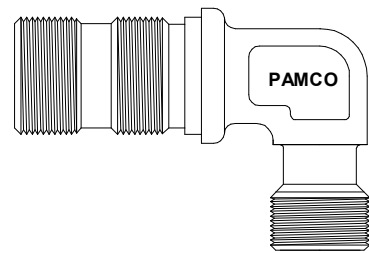

ELBOW, 90, BULKHEAD, REDUCED BODY, FLARELESS

AS4133

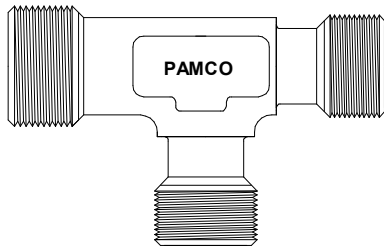

TEE, REDUCED BODY, FLARELESS

AS4134

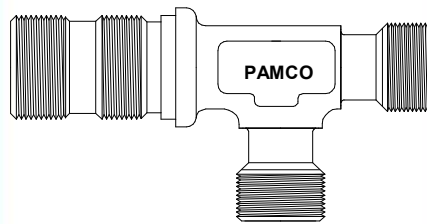

TEE, BULKHEAD ON RUN, REDUCED BODY, FLARELESS

AS4135

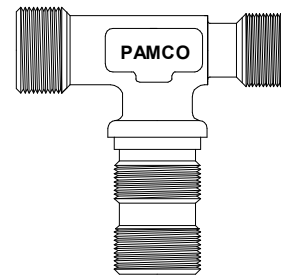

TEE, BULKHEAD ON SIDE, REDUCED BODY, FLARELESS



PRECISION AIRCRAFT MACHINING CO., INC

PHONE : (818) 768-5900

FAX: (818) 768-1409

AS4136

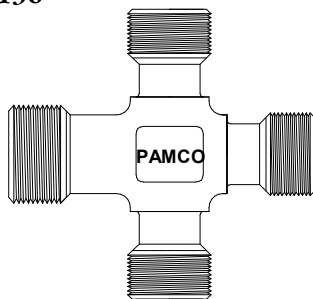

CROSS, REDUCED BODY, FLARELESS

AS4137

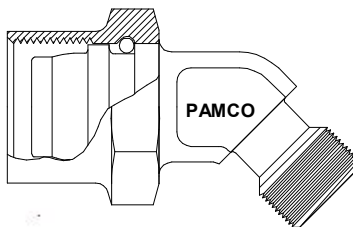

ELBOW, 45, SWIVEL, REDUCED BODY, FLARELESS

AS4138

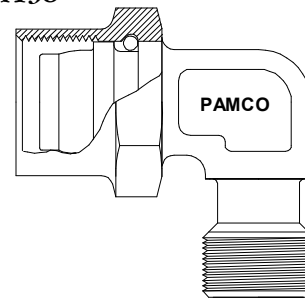

ELBOW, 90, SWIVEL, REDUCED BODY, FLARELESS

AS4139

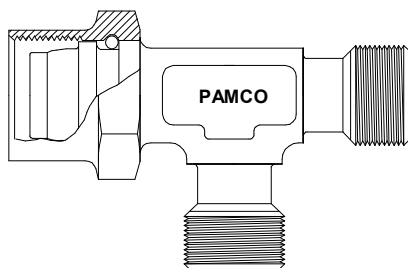

TEE, SWIVEL ON RUN, REDUCED BODY, FLARELESS

AS4140

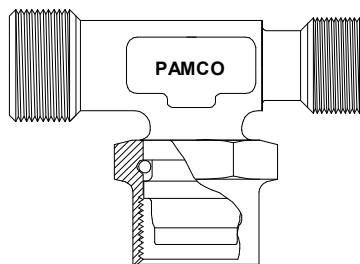

TEE, SWIVEL ON SIDE, REDUCED BODY, FLARELESS

AS4141

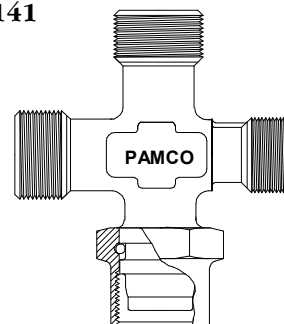

CROSS, SWIVEL ON SIDE, REDUCED BODY, FLARELESS



AS4211

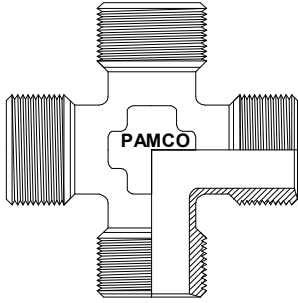

FITTING, CROSS, BEAM SEAL

AS4212

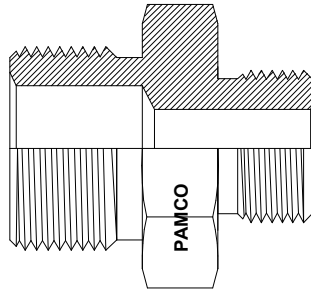

FITTING, UNION, REDUCER, BEAM SEAL

AS4213

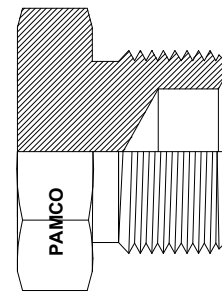

FITTING, PLUG, BEAM SEAL, HYDRAULIC

AS4214

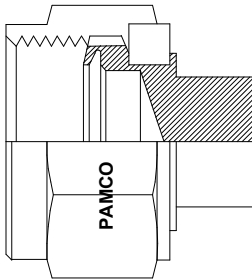

FITTING, CAP ASSEMBLY, BEAM SEAL, HYDRAULIC

AS4220

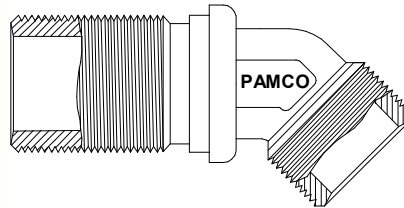

FITTING, ELBOW 45, BEAM SEAL, BULKHEAD

AS4221

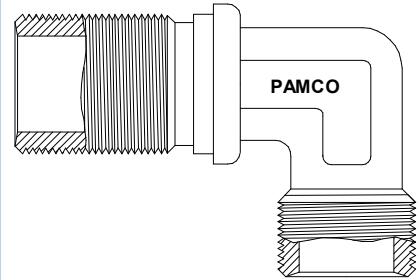

FITTING, ELBOW 90, BEAM SEAL, BULKHEAD



PRECISION AIRCRAFT MACHING CO., INC

PHONE : (818) 768-5900

FAX: (818) 768-1409

AS4222

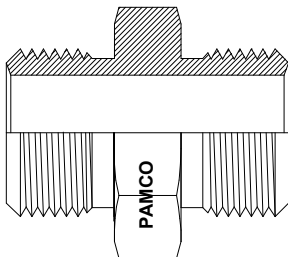

FITTING, UNION, BEAM SEAL

AS4223

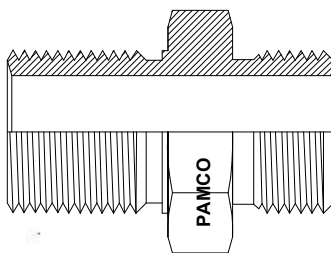

FITTING, UNION, BULKHEAD, BEAM SEAL

AS4224

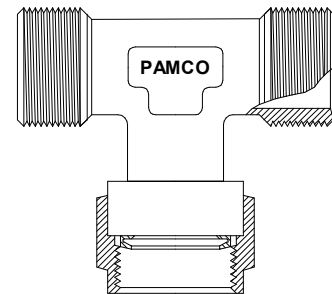

FITTING ASSEMBLY, TEE, RETAINED NUT ON SIDE

AS4300

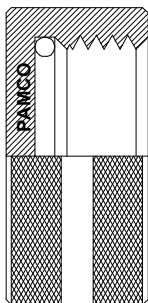

FITTING, ASSEMBLY

AS4301

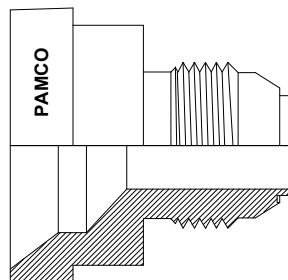

REDUCER-ADAPTER, CONICAL END TO FLARED TUBE

AS4302

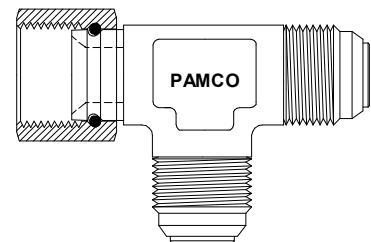

TEE ASSEMBLY, FLARED TUBE, RETAINED NUT ON RUN



AS4303

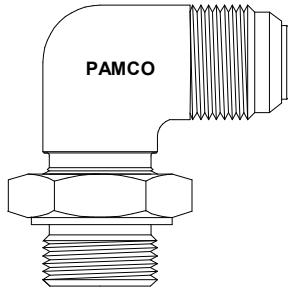

ELBOW ASSEMBLY 90, FLARED TUBE TO ADJUSTABLE

AS4304

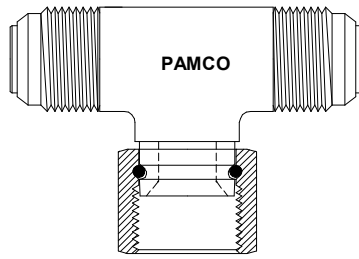

TEE ASSEMBLY, FLARED TUBE, RETAINED NUT ON SIDE

AS4305

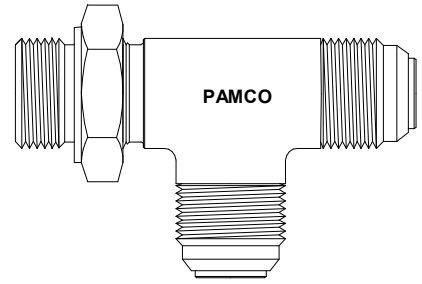

TEE ASSEMBLY, FLARED TUBE, ADJUSTABLE END ON

AS4306

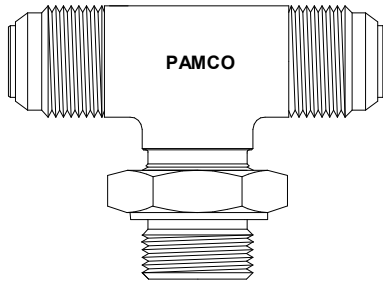

TEE ASSEMBLY, FLARED TUBE, ADJUSTABLE END ON

AS4307

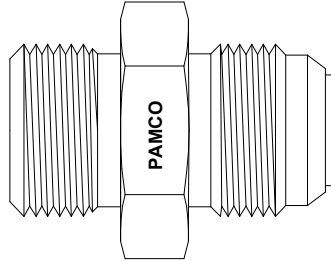

ADAPTER, FLARED TUBE TO BOSS, FOR SEAL RING

AS4308

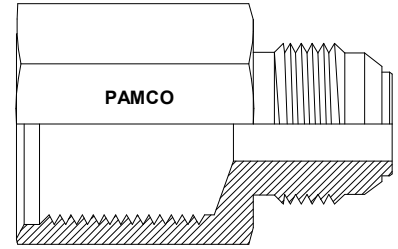

BUSHING-SCREW THREAD EXPANDER, FOR SEAL RING



PRECISION AIRCRAFT MACHING CO., INC

PHONE : (818) 768-5900

FAX: (818) 768-1409

AS4309

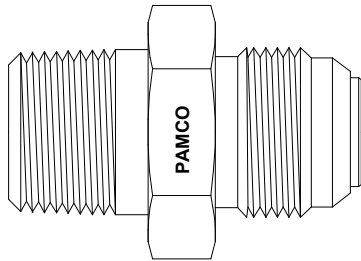

NIPPLE-FLARED TUBE TO PIPE THREAD, FOR SEAL RING

AS4310

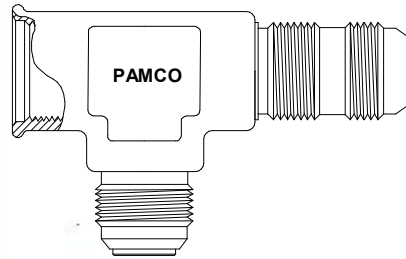

TEE-FLARED TUBE, INTERNAL THREAD ON RUN

AS4311

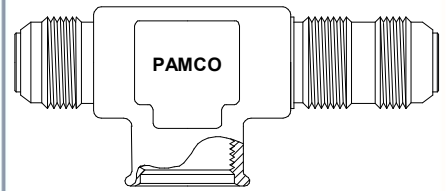

TEE-FLARED TUBE, INTERNAL THREAD ON SIDE

AS4312

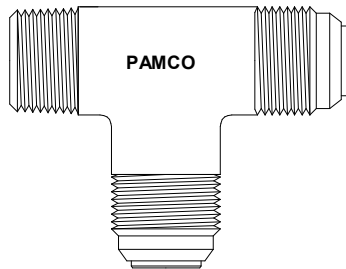

TEE-FLARED TUBE WITH PIPE, THREAD ON RUN

AS4313

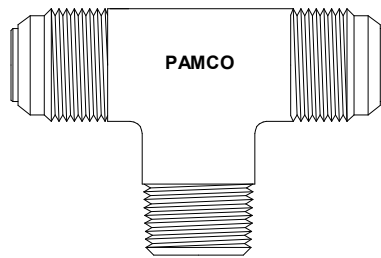

TEE-FLARED TUBE WITH PIPE THREAD ON SIDE

AS4314

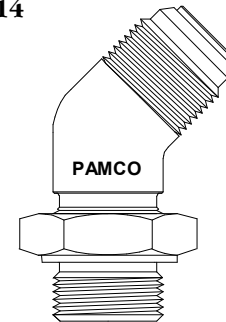

ELBOW ASSEMBLY 45, FLARED TUBE TO ADJUSTABLE END



WHEN QUALITY AND DELIVERY COUNT

AS4315

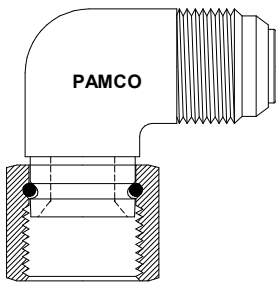

ELBOW ASSEMBLY 90, FLARED TUBE TO RETAINED NUT

AS4316

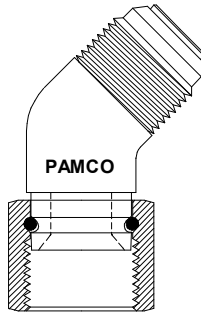

ELBOW ASSEMBLY 45, FLARED TUBE TO RETAINED NUT

AS4317

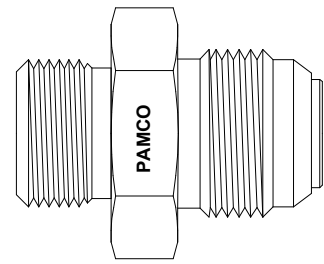

REDUCER, ADAPTER, FLARED TUBE TO BOSS

AS4318

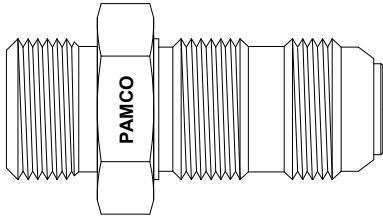

ADAPTER, FLARED TUBE .375 BULKHEAD TO BOSS

AS4319

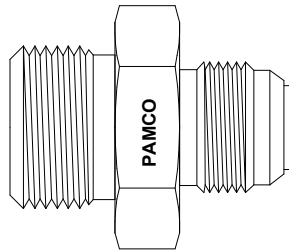

EXPANDER, ADAPTER, FLARED TUBE TO BOSS

AS4323

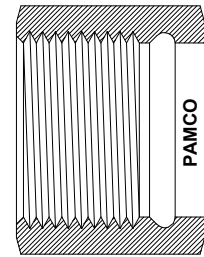

NUT, RETAINED, FOR FLARED TUBE FITTINGS



PRECISION AIRCRAFT MACHINING CO., INC

PHONE : (818) 768-5900

FAX: (818) 768-1409

AS4326

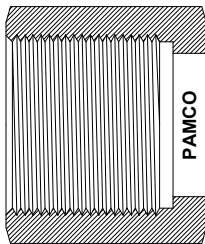

NUT, COUPLING

AS4327

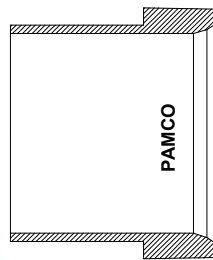

SLEEVE, FLARED TUBE FITTING

AS4328

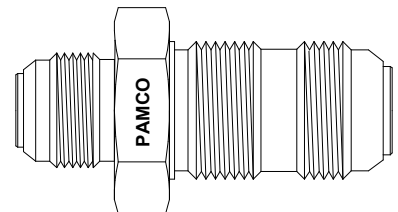

UNION, REDUCER, BULKHEAD, FLARED TUBE

AS4329

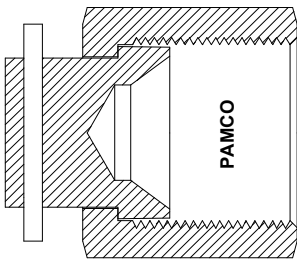

CAP, ASSEMBLY, PRESSURE SEAL, FLARED TUBE FITTING

AS4340

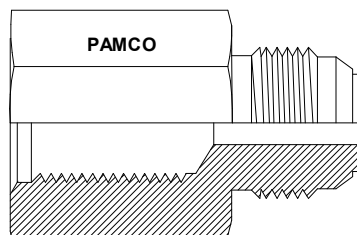

BUSHING-SCREW THREAD REDUCER, FOR SEAL RING

AS4346

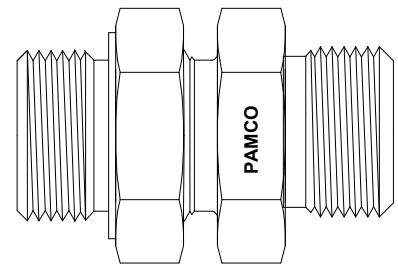

UNION, ASSEMBLY, ADJUSTABLE END



AS4347

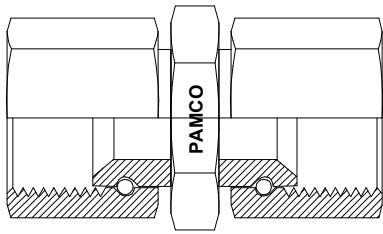

UNION, ASSEMBLY, DOUBLE RETAINED NUT

AS4348

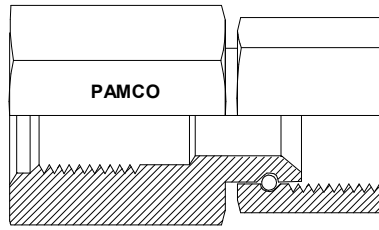

ADAPTER ASSEMBLY, RETAINED NUT TO BOSS

AS4349

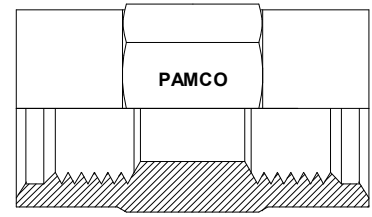

COUPLING, TUBE

AS4350

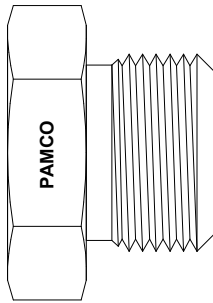

FITTING

AS4370

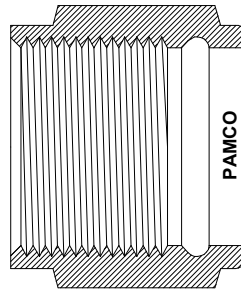

NUT, FITTING, RETAINED

AS4405

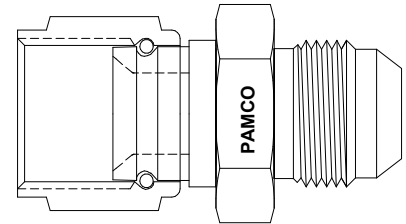

FITTING, ASSEMBLY, ADAPTER, REDUCER &



PRECISION AIRCRAFT MACHINING CO., INC

PHONE : (818) 768-5900

FAX: (818) 768-1409

AS4406

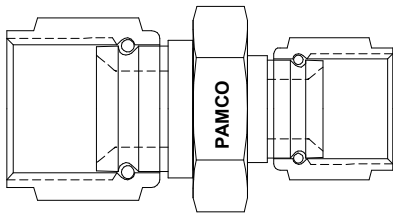

FITTING, ASSEMBLY, UNION, REDUCER & NONREDUCER

AS4407

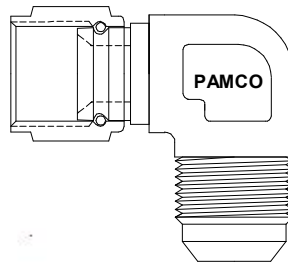

FITTING, ASSEMBLY, ELBOW 90, REDUCER &

AS4408

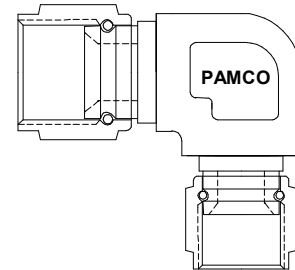

FITTING, ASSEMBLY, ELBOW 90, REDUCER &

AS4409

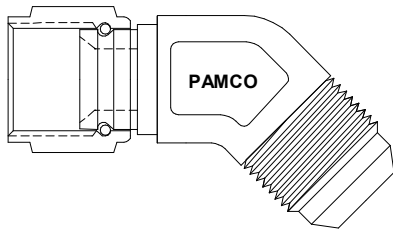

FITTING, ASSEMBLY, ELBOW 45, REDUCER & NONREDUCER

AS4410

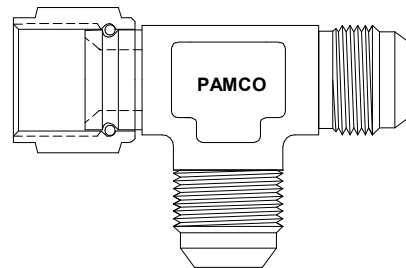

FITTING, ASSEMBLY, TEE, REDUCER & NONREDUCER

AS4411

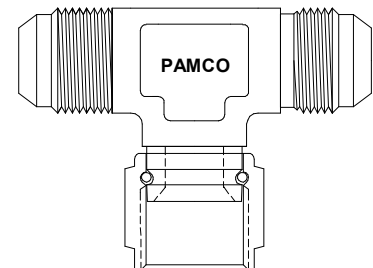

FITTING, ASSEMBLY, TEE, REDUCER & NONREDUCER

WHEN QUALITY AND DELIVERY COUNT



AS4541

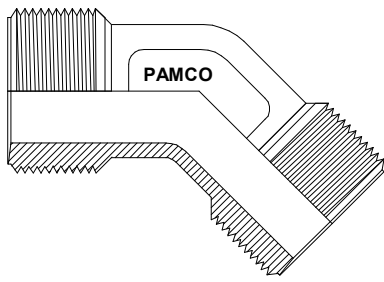

ELBOW, 45, BEAM SEAL, MALE 4000 PSI, HYDRAULIC

AS4542

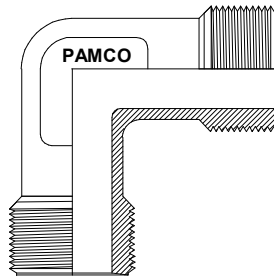

ELBOW, 90, BEAM SEAL, MALE 4000 PSI, HYDRAULIC

AS4660

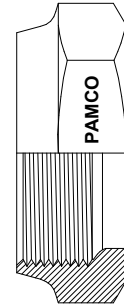

NUT, SHORT FLARELESS

AS4661

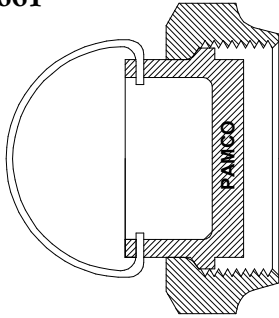

FITTING, ASSEMBLY, CAP, SHORT FLARELESS

AS4662

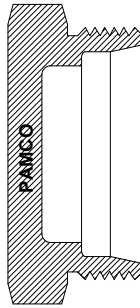

FITTING, PLUG, SHORT FLARELESS

AS4663

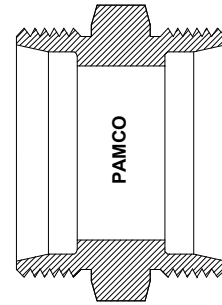

FITTING, UNION, SHORT FLARELESS



PRECISION AIRCRAFT MACHINING CO., INC

PHONE : (818) 768-5900

FAX: (818) 768-1409

AS4664

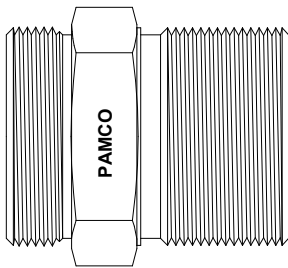

FITTING, UNION, BULKHEAD, SHORT FLARELESS

AS4665

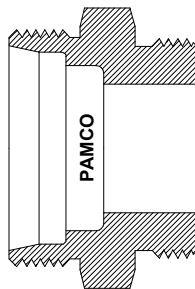

FITTING, ADAPTER, UNION & REDUCER, SHORT

AS4678

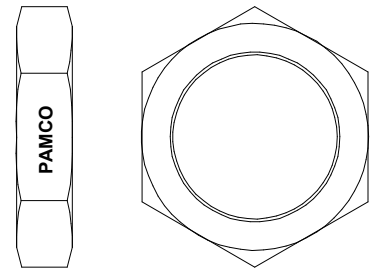

FITTING, NUT

AS4680

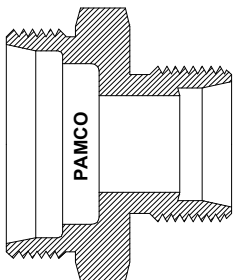

FITTING, UNION, REDUCER, SHORT FLARELESS TO BOSS

AS4681-1

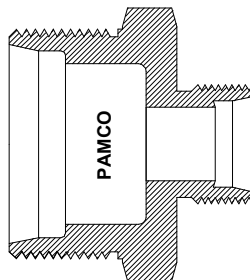

FITTING, UNION, REDUCER/EXPANDER BULKHEAD

AS4681-2

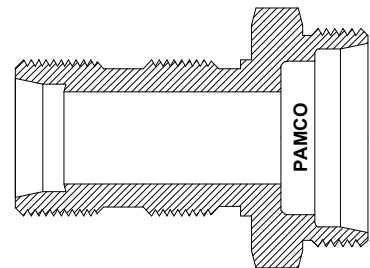

FITTING, UNION, REDUCER/EXPANDER BULKHEAD



AS4693

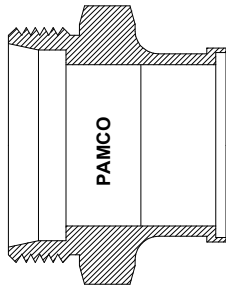

UNION, TUBE END, EXTERNAL THREAD TO WELD

AS4694

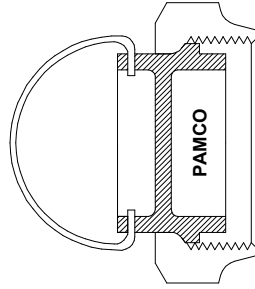

FITTING, ASSEMBLY, CAP, HOLLOW END, ACORN

AS4695

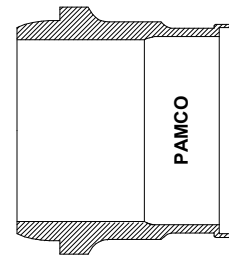

SLEEVE, TUBE END, ACORN TO WELD, SHORT FLARELESS

AS4696

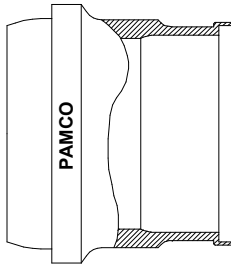

FITTING, SLEEVE, SHORT ACORN TO WELD TUBE END

AS4702

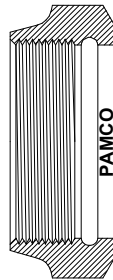

NUT, RETAINED, SHORT FLARELESS

AS4807

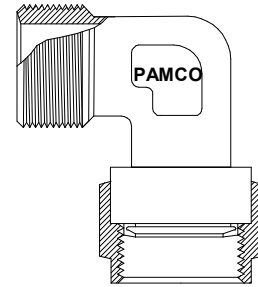

FITTING, ASSEMBLY, ELBOW 90, BEAM SEAL, RETAINED



PRECISION AIRCRAFT MACHINING CO., INC

PHONE : (818) 768-5900

FAX: (818) 768-1409

AS4808

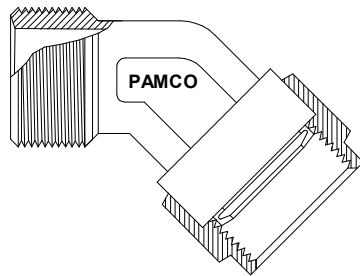

FITTING, ASSEMBLY, ELBOW 45, BEAM SEAL, RETAINED

AS4809

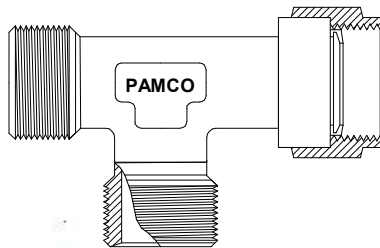

FITTING, ASLY, TEE, BEAM SEAL, RETAINED NUT ON RUN

AS4854

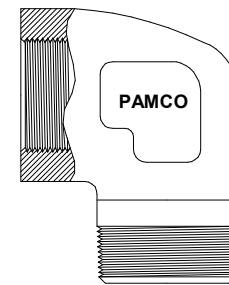

NUT, FITTING, RETAINED

AS4855

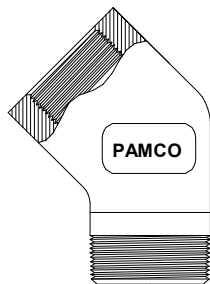

FITTING, ASSEMBLY, ADAPTER, REDUCER & NONREDUCER

AS4856

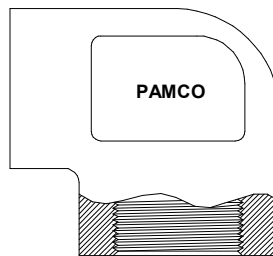

FITTING, ASSEMBLY, UNION, REDUCER & NONREDUCER

AS4857

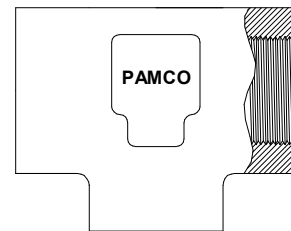

FITTING, ASSEMBLY, ELBOW 90, REDUCER & NONREDUCER

WHEN QUALITY AND DELIVERY COUNT





AS4858

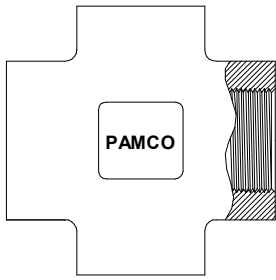

FITTING, ASSEMBLY, ELBOW 90, REDUCER &

AS4859

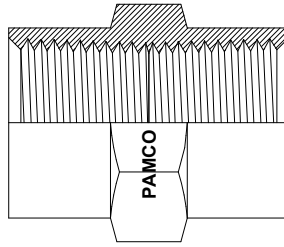

FITTING, ASSEMBLY, ELBOW 45, REDUCER &

AS4860

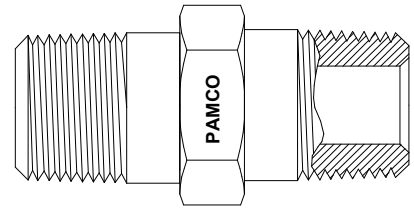

FITTING, ASSEMBLY, TEE, REDUCER & NONREDUCER

AS4861

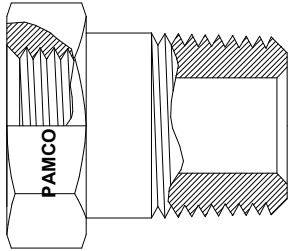

FITTING, ASSEMBLY, TEE, REDUCER & NONREDUCER

AS4862

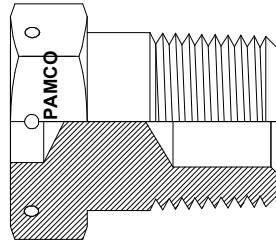

PLUG, PIPE, EXTERNAL THREAD, HEX HEAD

AS4863

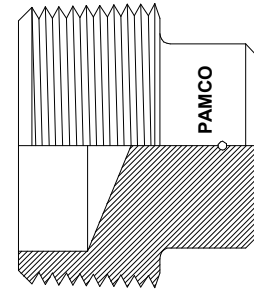

PLUG, PIPE, EXTERNAL THREAD



PRECISION AIRCRAFT MACHING CO., INC

PHONE : (818) 768-5900

FAX: (818) 768-1409

AS4971

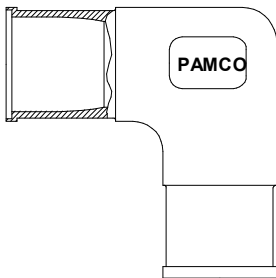

FITTING, ASSEMBLY, CAP, SHORT FLARELESS

AS4972

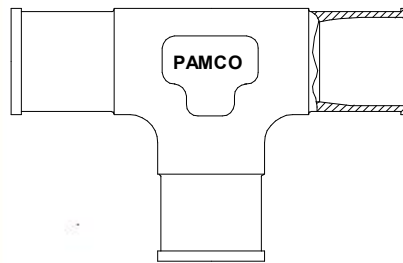

FITTING, PLUG, SHORT FLARELESS

AS4973

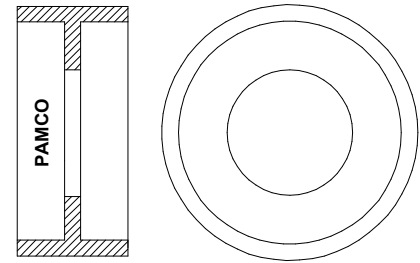

FITTING, UNION, SHORT FLARELESS



AS5002

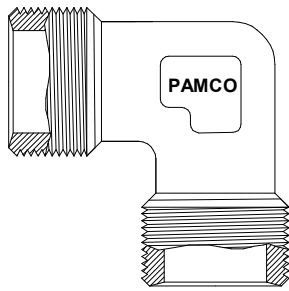

FITTING, ELBOW, 90, BEAM SEAL

AS5003

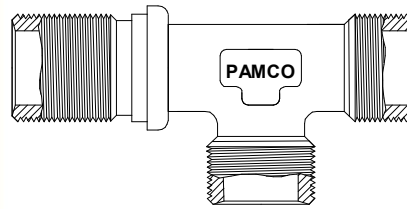

FITTING, TEE, BEAM SEAL, BULKHEAD ON RUN

AS5004

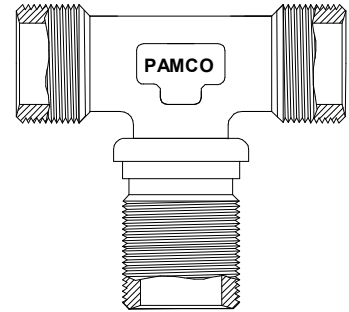

FITTING, TEE, BEAM SEAL BULKHEAD ON SIDE

AS5019

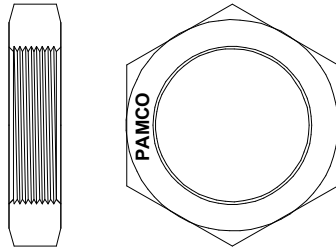

NUT, BULKHEAD, BEAM SEAL FITTING

AS5160

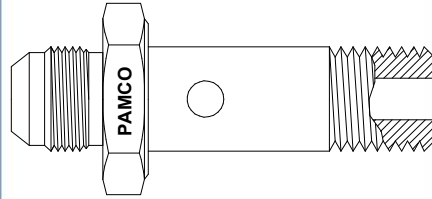

FITTING, BOLT, FLARED

AS5161

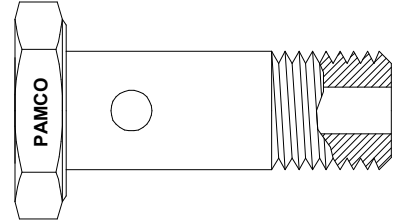

FITTING, BOLT, FLUID PASSAGE



PRECISION AIRCRAFT MACHINING CO., INC

PHONE : (818) 768-5900

FAX: (818) 768-1409

AS5162

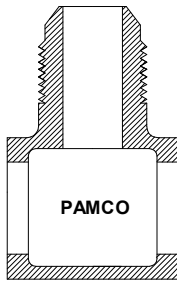

FITTING, CONNECTOR, MULTIPLE FLUID PRESSURE LINE

AS5163

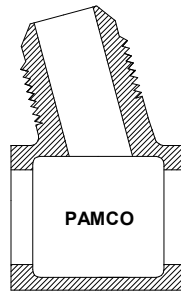

FITTING, CONNECTOR, MULTIPLE FLUID PRESSURE LINE

AS5164

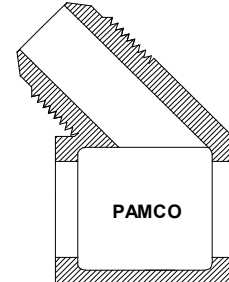

FITTING, CONNECTOR, MULTIPLE FLUID PRESSURE LINE

AS5165

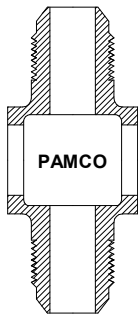

FITTING, CONNECTOR, MULTIPLE FLUID PRESSURE LINE TEE

AS5168

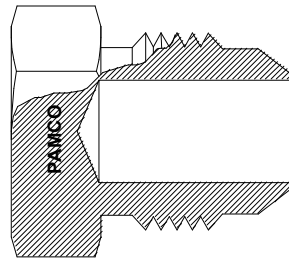

FITTING, PLUG, TUBE END, FLARED

AS5169

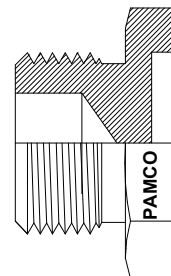

FITTING, PORT PLUG AND BLEEDER

WHEN QUALITY AND DELIVERY COUNT



AS5170

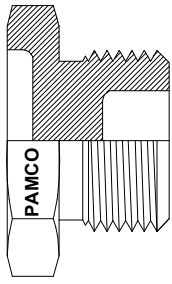

FITTING, PLUG, PORT, STRAIGHT THREAD, O-RING SEAL

AS5172

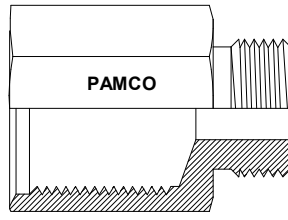

FITTING, ADAPTER, PORT, REDUCER

AS5173

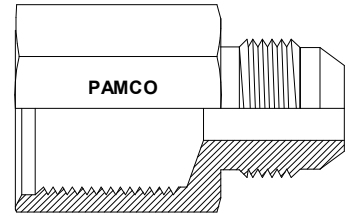

FITTING, BUSHING, PORT, REDUCER

AS5174

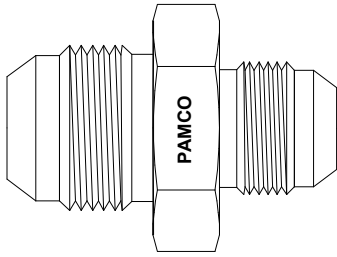

FITTING, UNION AND REDUCER, FLARED

AS5175

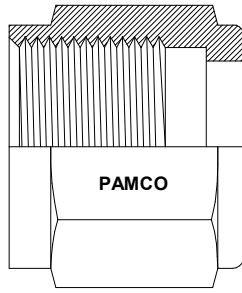

NUT, COUPLING, FLARED

AS5176



NUT, SLEEVE, FLARED



PRECISION AIRCRAFT MACHINING CO., INC

PHONE : (818) 768-5900

FAX: (818) 768-1409

AS5178



FITTING, NUT, BULKHEAD

AS5179



NUT, FITTING, PORT

AS5180

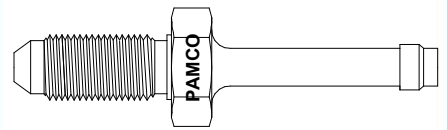

FITTING, ADAPTER, BULKHEAD, FLARED TO HOSE

AS5181

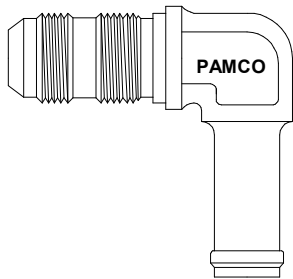

FITTING, ELBOW 90, BULKHEAD, FLARED TO HOSE

AS5182

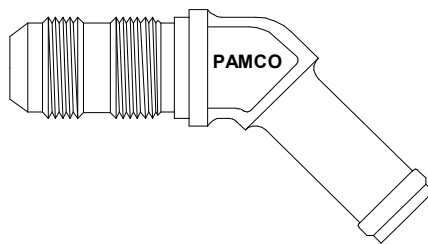

FITTING, ELBOW 45, BULKHEAD, FLARED TO HOSE

AS5183

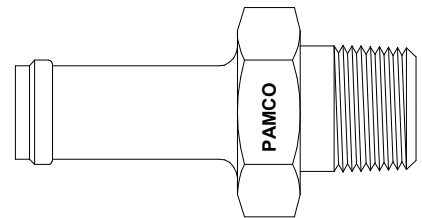

FITTING, ADAPTER, HOSE TO STRAIGHT PIPE



AS5184

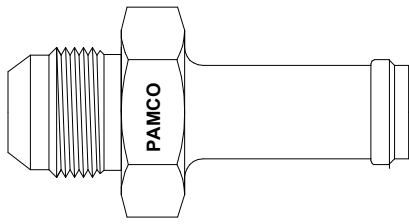

FITTING, ADAPTER, FLARED TO HOSE

AS5185

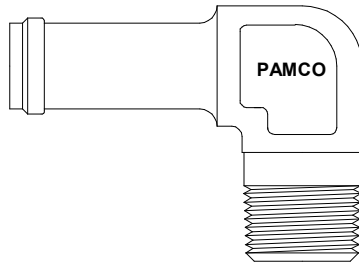

FITTING, ELBOW 90, PIPE TO HOSE

AS5186

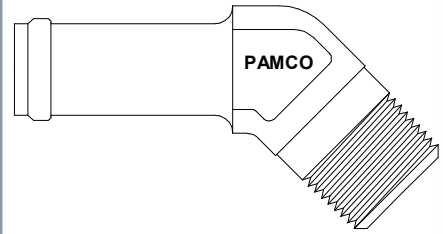

FITTING, ELBOW 45, PIPE TO HOSE

AS5187

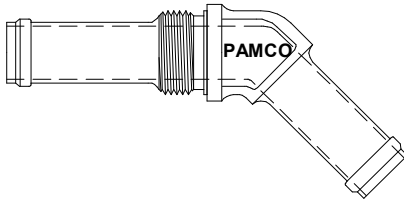

FITTING, ELBOW 45, BULKHEAD, HOSE

AS5188

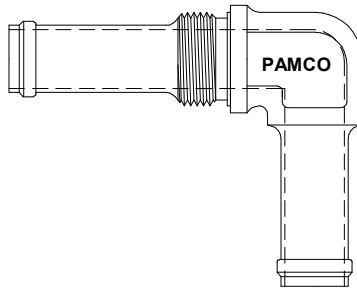

FITTING, ELBOW 90, BULKHEAD, HOSE

AS5189

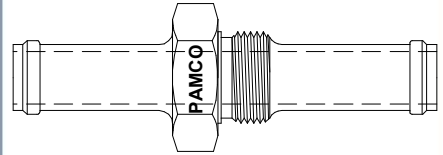

FITTING, ADAPTER, HOSE



PRECISION AIRCRAFT MACHINING CO., INC

PHONE : (818) 768-5900

FAX: (818) 768-1409

AS5190

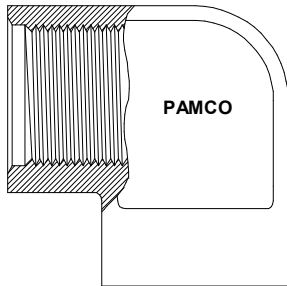

FITTING, ELBOW 90, INTERNAL STRAIGHT THREAD

AS5191

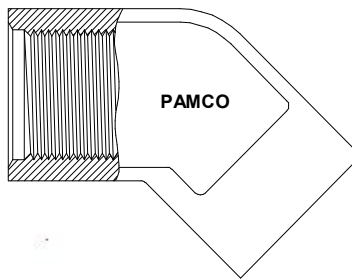

FITTING, ELBOW 45, INTERNAL STRAIGHT THREAD

AS5192

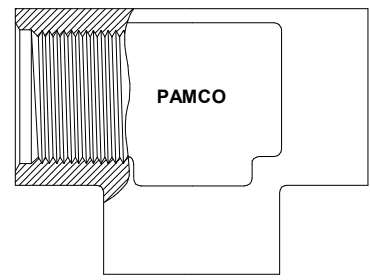

FITTING, TEE, INTERNAL STRAIGHT THREAD PORT

AS5193

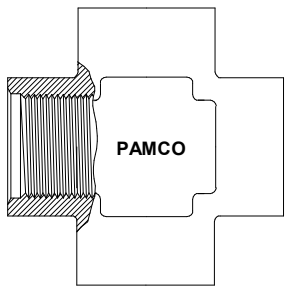

FITTING, CROSS, INTERNAL STRAIGHT THREAD PORT

AS5194

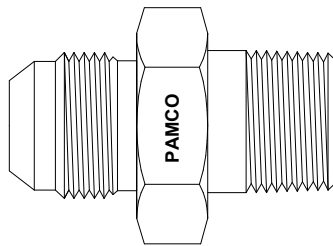

FITTING, ADAPTER, STRAIGHT PIPE TO FLARED

AS5195

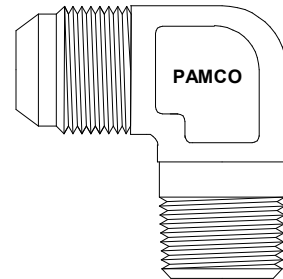

FITTING, ELBOW 90, FLARED TO PIPE

WHEN QUALITY AND DELIVERY COUNT



AS5196

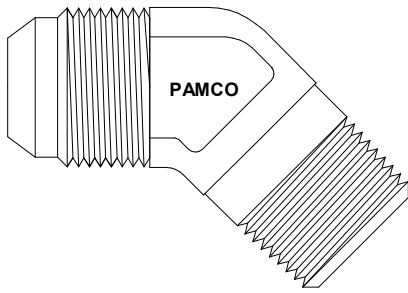

FITTING, ELBOW 45, FLARED TO PIPE

AS5197

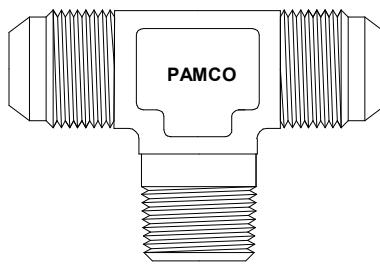

FITTING, TEE, FLARED TO PIPE ON SIDE

AS5198

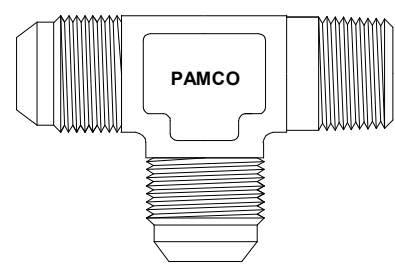

FITTING, TEE, FLARED TO PIPE ON RUN

AS5205

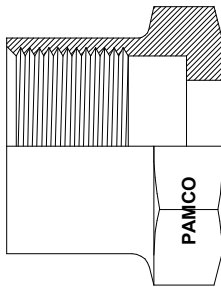

NUT, FITTING, ENGINE, FLARED

AS5206

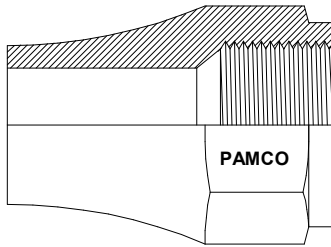

NUT, FLARED, LONG

AS5227

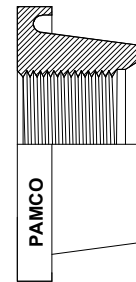

FLANGE, STRAIGHT THREAD PORT, WELD



PRECISION AIRCRAFT MACHINING CO., INC

PHONE : (818) 768-5900

FAX: (818) 768-1409

AS5230

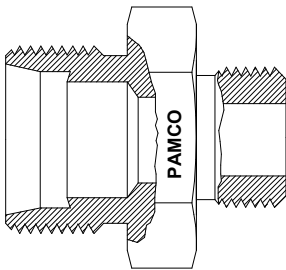

FITTING, UNION & REDUCER, FLARELESS

AS5231

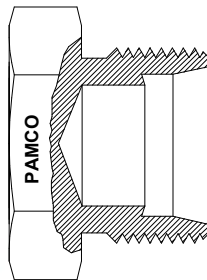

NUT, FITTING, PORT

AS5232

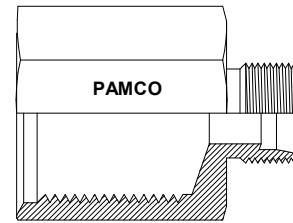

FITTING, ADAPTER, BULKHEAD, FLARED TO HOSE

AS5233

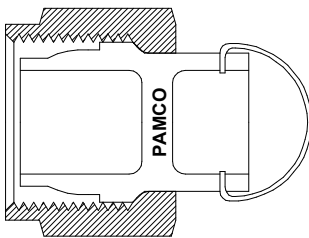

FITTING, ELBOW 90, BULKHEAD, FLARED TO HOSE

AS5238

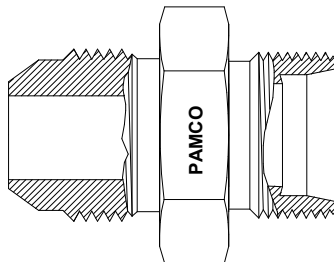

FITTING, ELBOW 45, BULKHEAD, FLARED TO HOSE

AS5239

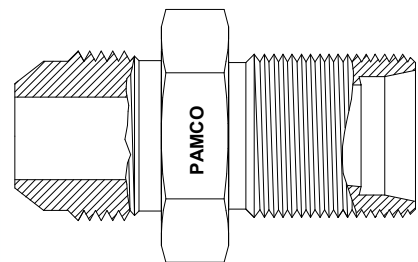

FITTING, ADAPTER, BULKHEAD, FLARELESS TO FLARED



AS5240

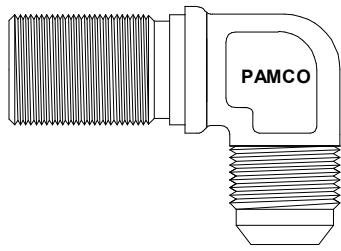

FITTING, ELBOW 90, BULKHEAD, FLARELESS TO FLARED

AS5241

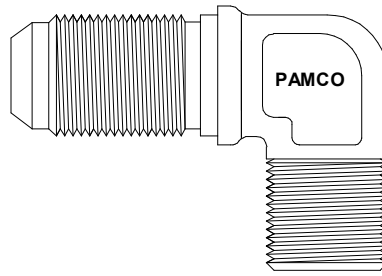

FITTING, ELBOW 90, BULKHEAD, FLARELESS TO FLARED

AS5242

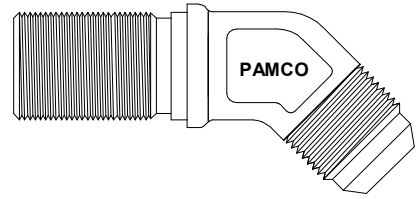

FITTING, ELBOW 45, BULKHEAD, FLARELESS TO FLARED

AS5406

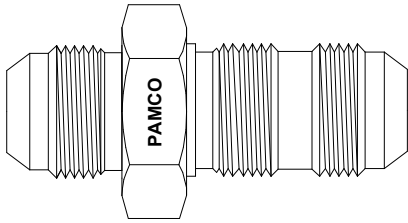

FITTING, UNION, TUBE, .375 BULKHEAD



PRECISION AIRCRAFT MACHINING CO., INC

PHONE : (818) 768-5900

FAX: (818) 768-1409



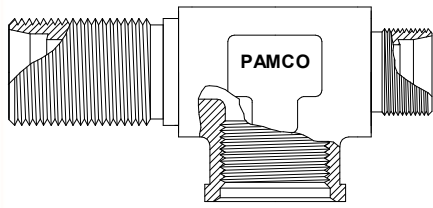

AS6041

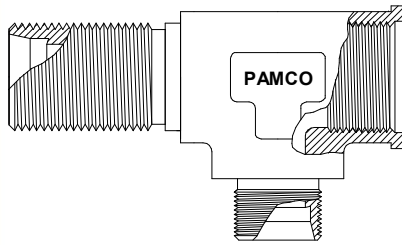

FITTING, TEE, STANDARD AND REDUCER

AS6042



FITTING, TEE, STANDARD AND REDUCER

AS6043

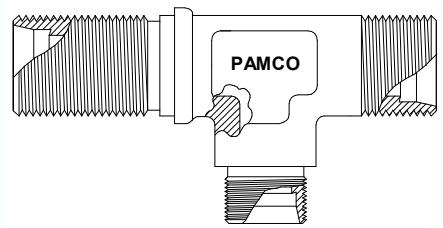

FITTING, TEE, STANDARD AND REDUCER

AS6044

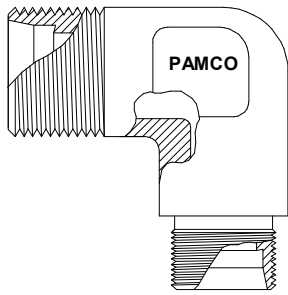

FITTING, ELBOW, 90° STANDARD AND REDUCER

AS6045

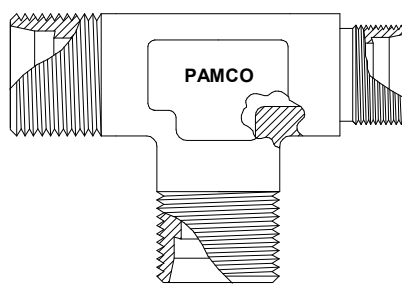

FITTING, TEE, STANDARD AND REDUCER

AS6046

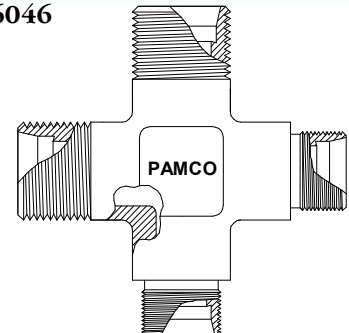

FITTING, CROSS, STANDARD AND REDUCER



PHONE : (818) 768-5900

FAX: (818) 768-1409

AS6047

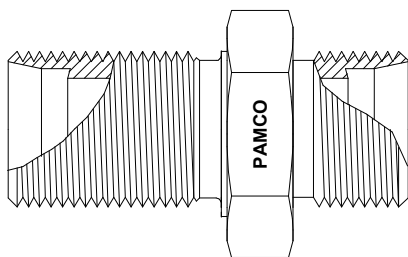

FITTING, UNION, STANDARD AND REDUCER

AS6048

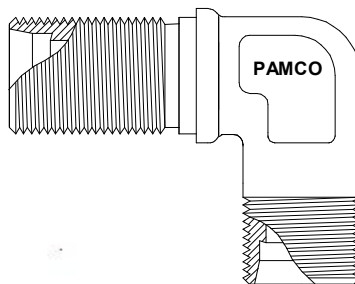

FITTING, ELBOW, 90° STANDARD AND REDUCER

AS6049

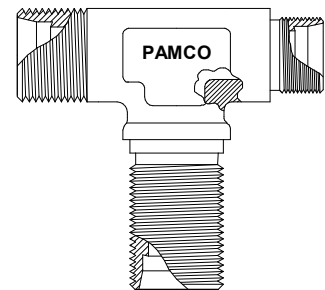

FITTING, TEE, STANDARD AND REDUCER







PHONE : (818) 768-5900  
FAX: (818) 768-1409





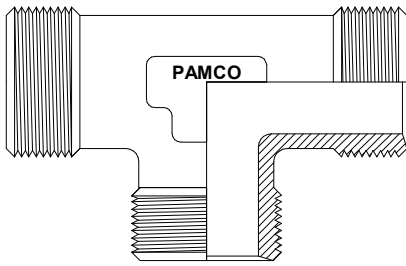

AS85421/3

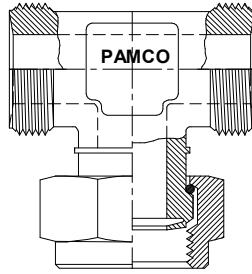

FITTING, TEE, REDUCER, BEAM SEAL, 3 MALE ENDS

AS85421/4



FITTING, TEE, REDUCER & NON-REDUCER, BEAM SEAL

AS85421/5

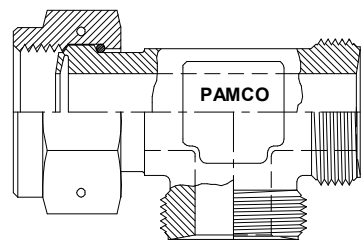

FITTING, TEE, REDUCER & NON-REDUCER, BEAM SEAL

AS85421/6

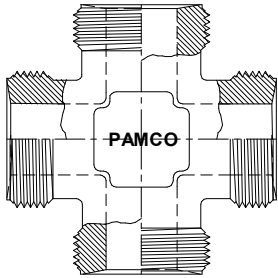

FITTING, CROSS, BEAM SEAL, MALE ENDS

AS85421/7

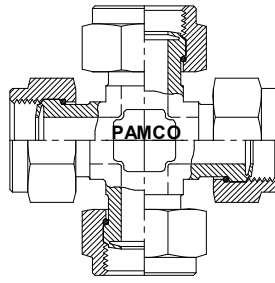

FITTING ASSEMBLY, CROSS, BEAM SEAL, 4 FEMALE ENDS

AS85421/8

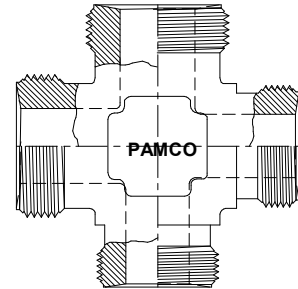

FITTING, CROSS, REDUCER, BEAM SEAL, 4 MALE ENDS



PRECISION AIRCRAFT MACHINING CO., INC

PHONE : (818) 768-5900

FAX: (818) 768-1409

AS85421/9

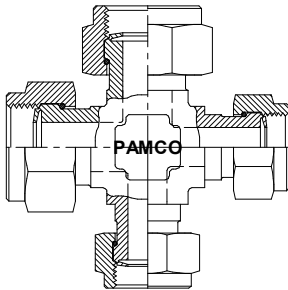

FITTING ASSEMBLY, CROSS, REDUCER, 4 FEMALE ENDS

AS85421/10

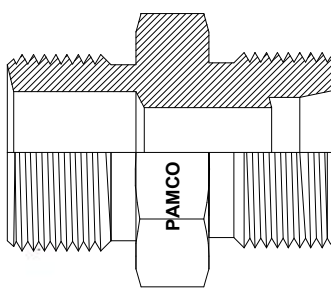

FITTING, ADAPTER, BEAM SEAL, MALE TO FLARELESS

AS85421/11

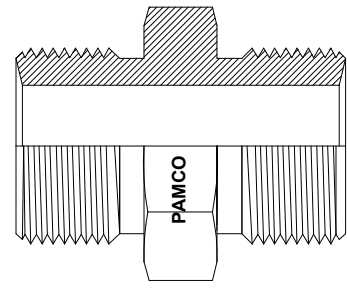

FITTING, UNION, BEAM SEAL, MALE ENDS

AS85421/12

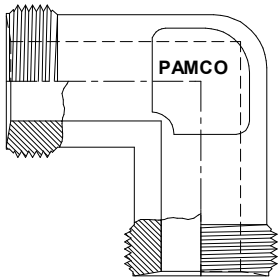

FITTING, ELBOW, 90, BEAM SEAL, MALE TO MALE

AS85421/13

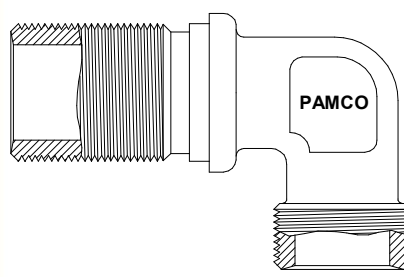

FITTING, ELBOW, 90, BEAM SEAL, BULKHEAD, M-ENDS

AS85421/14

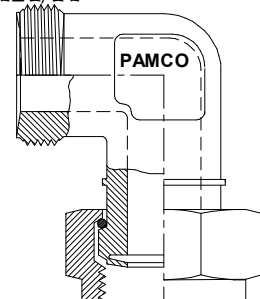

FITTING, ELBOW, 90, BEAM SEAL, MALE TO-FEMALE



AS85421/15

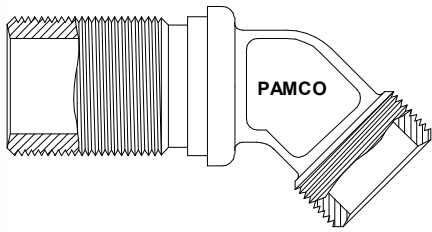

FITTING, ELBOW, 45, BEAM SEAL, BULKHEAD, M-ENDS

AS85421/16

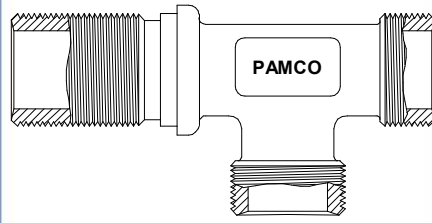

FITTING, TEE, BEAM SEAL, BULKHEAD ON RUN, M-ENDS

AS85421/17

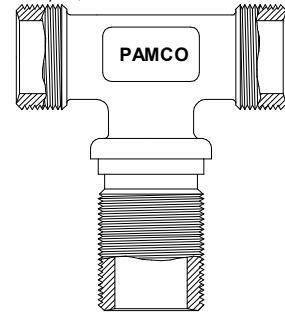

FITTING, TEE, BEAM SEAL, BULKHEAD ON BRANCH, M-ENDS

AS4213

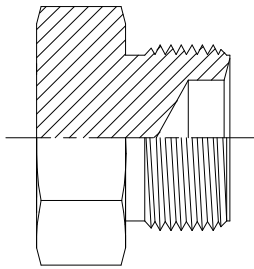

FITTING, PLUG, BEAM SEAL, HYDRAULIC

AS4214

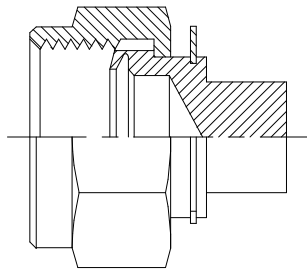

FITTING, CAP ASSEMBLY, BEAM SEAL, HYDRAULIC



PRECISION AIRCRAFT MACHINING CO., INC

PHONE : (818) 768-5900

FAX: (818) 768-1409

AS9002

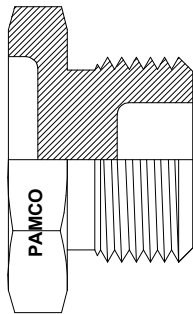

PLUG, MACHINE THREAD DRILLED

WHEN QUALITY AND DELIVERY COUNT



NAS1237

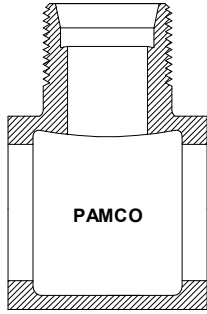

ELBOW - UNIVERSAL 90 -FLARELESS

NAS1238

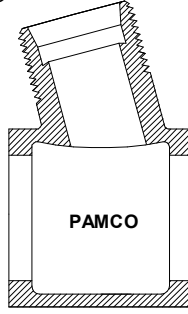

ELBOW - UNIVERSAL 75 -FLARELESS

NAS1239

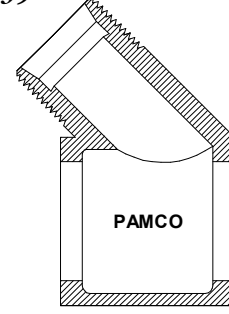

ELBOW - UNIVERSAL 45 -FLARELESS

NAS1240

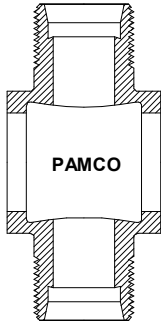

TEE - UNIVERSAL -FLARELESS

NAS1761

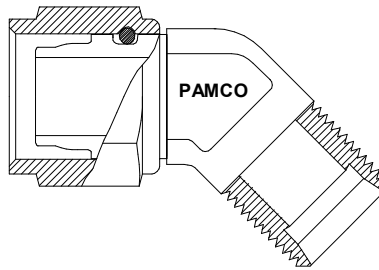

ELBOW, REDUCER, 45, FLARELESS TUBE TO SWIVEL

NAS1762

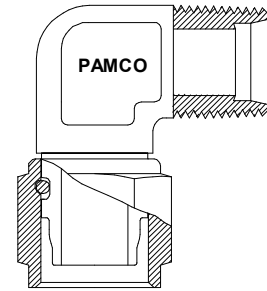

ELBOW, REDUCER, 90, FLARELESS TUBE TO SWIVEL



PRECISION AIRCRAFT MACHING CO., INC

PHONE : (818) 768-5900

FAX: (818) 768-1409

NAS1763

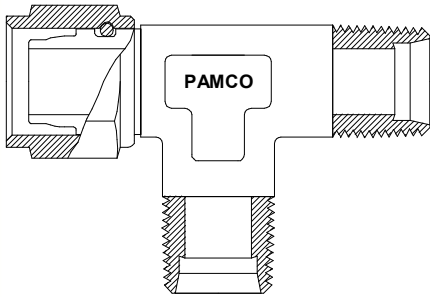

TEE, REDUCER, FLARELESS TUBE TO SWIVEL

NAS1764

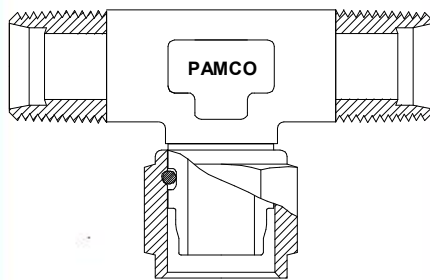

TEE, REDUCER, FLARELESS TUBE TO SWIVEL, ON SIDE

NAS424

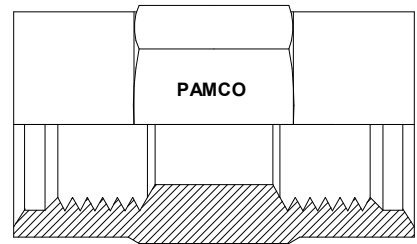

COUPLING, TUBE, FLARELESS FITTING, FEMALE THREAD

NAS551

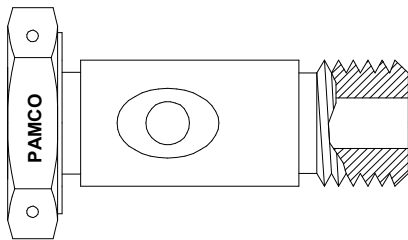

BOLT, UNIVERSAL FITTING

NAS552

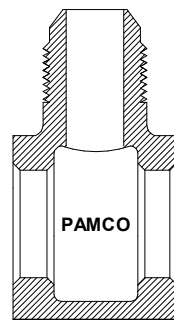

ELBOW, UNIVERSAL 90 DEGREE

NAS553

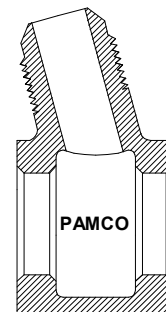

ELBOW, UNIVERSAL 15 DEGREE



NAS555

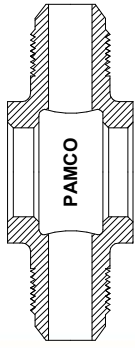

TEE, UNIVERSAL

NAS591

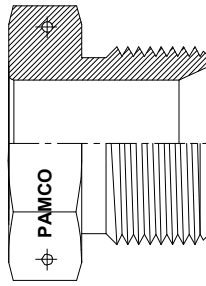

COUPLING, RIGID TUBE CONNECTOR, ALUMINUM

NAS593

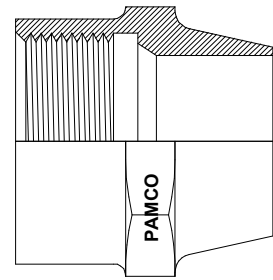

NUT, RIGID TUBE CONNECTOR, ALUMINUM

NAS594

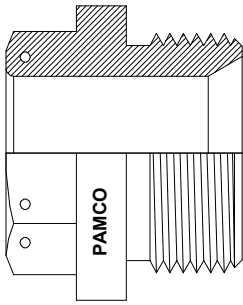

COUPLING, RIGID TUBE CONNECTOR, CRES

NAS595

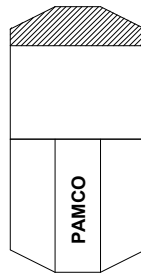

RING, RIGID TUBE CONNECTOR, CRES

NAS596

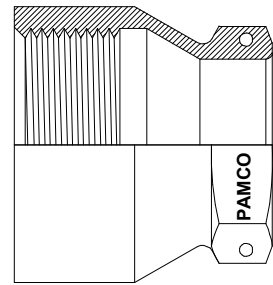

NUT, RIGID TUBE CONNECTOR, CRES



PRECISION AIRCRAFT MACHINING CO., INC

PHONE : (818) 768-5900

FAX: (818) 768-1409

MS20756

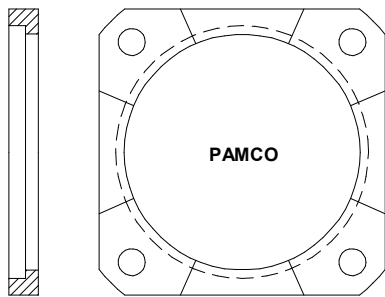

SWIVEL FITTING FLANGE SIZE 12 THROUGH 32

MS20756

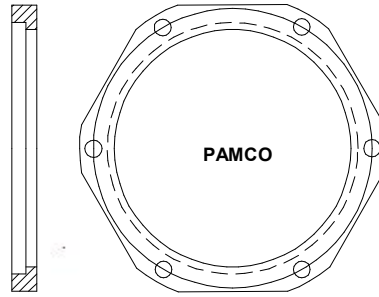

SWIVEL FITTING FLANGE SIZE 40 THROUGH 48

MS20756

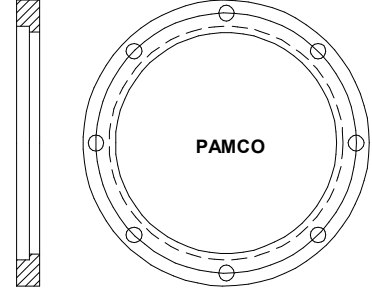

SWIVEL FITTING FLANGE SIZE 56 THROUGH 112

WHEN QUALITY AND DELIVERY COUNT





## References



PRECISION AIRCRAFT MACHINING CO., INC.

# PAMCO

AS cross reference chart

**AS9100 CERTIFIED**  
**AS18280 QPL**

WE ARE IN BUSINESS FOR OUR CUSTOMERS

CANCELLED AN & MS PARTS	SUPERSEDED AS PART NUMBERS
----------------------------	-------------------------------

AN774	AS5160
AN775	AS5161
AN776	AS5162
AN777	AS5163
AN778	AS5164
AN779	AS5165
AN783/MS24388	AS1031
AN784/MS24389	AS1032
AN804/MS24390	AS1033
AN806/MS24404	AS5168
AN807	AS5180
AN814/MS24391	AS5169
AN815/MS24392	AS5174
AN816	AS5194
AN817	AS5206**
AN818	AS5175**
AN821/MS24401	AS1034
AN824/MS24402	AS1035
AN827/MS24403	AS1036
AN832/MS24393	AS1037
AN833/MS24394	AS1038
AN834/MS24395	AS1039
AN837/MS24396	AS1040
AN838	AS5181
AN839	AS5182
AN840	AS5183
AN841	AS5184
AN842	AS5185
AN844	AS5186
AN846	AS5187
AN848	AS5188
AN849	AS5189

\*\* RELEASE PENDING

CANCELLED AN & MS PARTS	SUPERSEDED AS PART NUMBERS
----------------------------	-------------------------------

AN871	AS5227
AN893/MS24397	AS5172
AN894/MS24398	AS5173
AN910	AS4859
AN911	AS4860
AN912	AS4861
AN913/MS20913	AS4863
AN914	AS4854
AN915	AS4855
AN916	AS4856
AN917	AS4857
AN918	AS4858
AN919/MS24399	AS5174
AN924	AS5178
AN929	AS5177**
AN932	AS4864**
AN933	AS4862
AN937	AS5193
AN938	AS5192
AN939	AS5190
AN941	AS5191
AN6289	AS5179
MS20756	AS5220**
MS20757	AS5221**
MS20758	AS5122**
MS20759	AS5123**
MS20760	AS5124**
MS20819	AS5176
MS20822	AS5195
MS20823	AS5196
MS20825	AS5197
MS20826	AS5198



PRECISION AIRCRAFT MACHINING CO., INC

**PAMCO**

**PAMCO**

Master List of Basic  
AN, MS, NAS & AS Numbers



# PAMCO



WE ARE IN BUSINESS FOR OUR CUSTOMERS

“As parts of PAMCO’s ongoing effort to improve its products and services, its reserves the right to make changes to any of the products and materials appearing in this catalog, without prior notice.”



© PAMCO 2015 All rights reserved